

Contents

Autodesk AliasStudio 2009

Transition Guide for users of ICEM software

Introduction 1

AliasStudio Interface Tips 2

Sculpting NURBS Surfaces 7

Faces, Trims and Curves-on-Surface 17

Matching Surfaces: G0, G1, G2 23

Building with Curves & Surfaces 31

Organizing Data 43

Copyright and trademarks

March 2008

© 2008 Autodesk, Inc. All Rights Reserved. Except as otherwise permitted by Autodesk, Inc., this publication, or parts thereof, may not be reproduced in any form, by any method, for any purpose.

Certain materials included in this publication are reprinted with the permission of the copyright holder.

Trademarks

The following are registered trademarks or trademarks of Autodesk, Inc., in the USA and other countries: 3DEC (design/logo), 3December, 3December.com, 3ds Max, ActiveShapes, Actrix, ADI, Alias, Alias (swirl design/logo), AliasStudio, Alias|Wavefront (design/logo), ATC, AUGI, AutoCAD, AutoCAD Learning Assistance, AutoCAD LT, AutoCAD Simulator, AutoCAD SQL Extension, AutoCAD SQL Interface, Autodesk, Autodesk Envision, Autodesk Insight, Autodesk Intent, Autodesk Inventor, Autodesk Map, Autodesk MapGuide, Autodesk Streamline, AutoLISP, AutoSnap, AutoSketch, AutoTrack, Backdraft, Built with ObjectARX (logo), Burn, Buzzsaw, CAICE, Can You Imagine, Character Studio, Cinestream, Civil 3D, Cleaner, Cleaner Central, ClearScale, Color Warper, Combustion, Communication Specification, Constructware, Content Explorer, Create>what's>Next> (design/logo), Dancing Baby (image), DesignCenter, Design Doctor, Designer's Toolkit, DesignKids, DesignProf, DesignServer, DesignStudio, DesignStudio (design/logo), Design Your World, Design Your World (design/logo), DWF, DWG, DWG (logo), DWG TrueConvert, DWG TrueView, DXF, EditDV, Education by Design, Exposure, Extending the Design Team, FBX, Filmbox, FMDesktop, Freewheel, GDX Driver, Gmax, Heads-up Design, Heidi, HOOPS, HumanIK, i-drop, iMOUT, Incinerator, IntroDV, Inventor, Inventor LT, Kaydara, Kaydara (design/logo), LocationLogic, Lustre, Maya, Mechanical Desktop, MotionBuilder, Mudbox, NavisWorks, ObjectARX, ObjectDBX, Open Reality, Opticore, Opticore Opus, PolarSnap, PortfolioWall, Powered with Autodesk Technology, Productstream, ProjectPoint, ProMaterials, Reactor, RealDWG, Real-time Roto, Recognize, Render Queue, Reveal, Revit, Showcase, ShowMotion, SketchBook, SteeringWheels, StudioTools, Topobase, Toxik, ViewCube, Visual, Visual Bridge, Visual Construction, Visual Drainage, Visual Hydro, Visual Landscape, Visual Roads, Visual Survey, Visual Syllabus, Visual Toolbox, Visual Tugboat, Visual LISP, Voice Reality, Volo, Wiretap, and WiretapCentral

The following are registered trademarks or trademarks of Autodesk Canada Co. in the USA and/or Canada and other countries: Backburner, Discreet, Fire, Flame, Flint, Frost, Inferno, Multi-Master Editing, River, Smoke, Sparks, Stone, and Wire

All other brand names, product names or trademarks belong to their respective holders.

Disclaimer

THIS PUBLICATION AND THE INFORMATION CONTAINED HEREIN IS MADE AVAILABLE BY AUTODESK, INC. "AS IS." AUTODESK, INC. DISCLAIMS ALL WARRANTIES, EITHER EXPRESS OR IMPLIED, INCLUDING BUT NOT LIMITED TO ANY IMPLIED WARRANTIES OF MERCHANTABILITY OR FITNESS FOR A PARTICULAR PURPOSE REGARDING THESE MATERIALS.

Published by:

Autodesk, Inc.
111 McInnis Parkway
San Rafael, CA 94903, USA

Third-Party Copyright Notices

This product includes software developed by the Apache Software Foundation.

Macromedia Shockwave™ Player and Macromedia Flash™ Player software by Macromedia, Inc., Copyright © 1995-2000 Adobe Systems Incorporated. All rights reserved.

Portions relating to JPEG Copyright © 1991-1998 Thomas G. Lane. All rights reserved. This software is based in part on the work of the Independent JPEG Group.

Portions relating to TIFF Copyright © 1997-1998 Sam Leffler. Copyright © 1991-1997 Silicon Graphics, Inc. All rights reserved.

GOVERNMENT USE

Use, duplication, or disclosure by the U.S. Government is subject to restrictions as set forth in FAR 12.212 (Commercial Computer Software-Restricted Rights) and DFAR 227.7202 (Rights in Technical Data and Computer Software), as applicable.

Introduction

1

Welcome to the ICEM to AliasStudio Transition Guide. Designed for technical surfacing professionals, this guide focuses on the key tools and techniques required to build Class A surfaces.

Before you read this guide, we recommend that you read the Getting Started guide. This will give you the fundamental tools for viewing and zooming, using the menus and palettes, and picking and moving objects.

It will also show you how to install and use the on-line help, which gives you access to all the reference manuals and tutorials.

Reference Card

Ideally you will have access to AliasStudio while reading this guide, and be able to practice and learn the workflows presented. To help you, a Reference Card is provided at the rear of this guide for you to pull out and use to help remember the keyboard and mouse combinations described.

Further Tutorials

After you read this guide, you may want to look at the Technical Surfacing tutorial provided as HTML and as a PDF in the on-line help. This has detailed examples of how the tools are used in typical modeling scenarios.

If you are interested in using AliasStudio for rendering and animation, or as a general CAD system, you can select the relevant tutorials in the Learning AliasStudio guide.

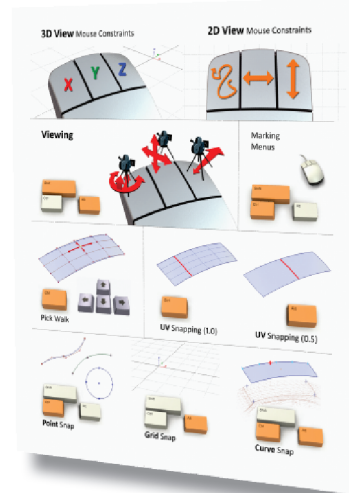

The guide starts with some hints and tips on using and simplifying the AliasStudio interface.

Using the interface

Read the Prompt Line...

Many people prefer to learn by experimenting, rather than reading reference manuals. The AliasStudio tools are well designed, and often you will be able to use them just by trying them out. The key is to always read the Prompt Line, where a tool will guide you through the steps and selections you need to make.

Unlike ICEM, the Prompt Line is at the top of the AliasStudio screen. This location cannot be modified or customized.

To view previous prompt messages, you can open the Prompt Line History by clicking on the text symbol to the left of the prompt line. This can help you understand why a tool has failed, or to review the input sequence required for a tool.

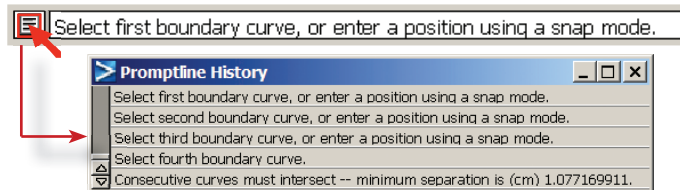

The prompt line always requests the type of input a tool needs, for example a curve, or a vector. This is used instead of the selection window workflow in ICEM.

Option Windows

In ICEM, option windows appear automatically when a tool is selected, and stay on screen as long as the tool is being used.

In AliasStudio you need to specifically open the option window by either double-clicking on an icon, or moving the mouse to the square symbol (□) on a menu.

A short-cut for both is to hold the Shift key down when selecting the tool.

Some tools have a simple and an advanced tab; use the advanced tab to access all the available options.

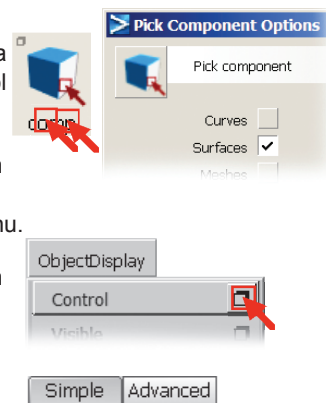

Palette & Shelf

The Palette contains all the modeling tools and is designed as the standard user interface that you will see on any installation of AliasStudio.

The Shelf is designed to be customized by each individual user to suit their preferred way of working. Tools from the Palette can be dragged onto the shelf and arranged in tabs. Experienced users will build up their own customized Shelf over many months, and eventually it may replace the Palette altogether in their workflow.

The Shelf that appears when you first open AliasStudio is intended only as an example of how you may customize the tools. There is a danger that you waste time learning the location of tools on the Palette and the Shelf! So, we recommend that you close the shelf when you start to learn the software, and later create your own shelf to suit your preferred workflow.



...the default Shelf has **duplicates** of the Palette tools – don't try to learn the Shelf tools

Choose the Palette Position

Initially the Palette is positioned on the left of the screen, floating above the workspace.

To locate the Palette tools at the bottom of the screen (similar to the Geometry Block location in ICEMsurf), use **Preferences > Interface > Palette/Shelves Layout** and set your preference in the option window.

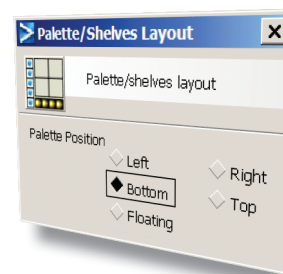

Marking Menus

The marking menus have duplicates of common tools, such as Pick, Move and Rotate. Using the Marking Menus is optional – many new users choose to ignore them initially, in order to reduce the complexity of the interface. Most experienced users will create their own, customized marking menus and use them to speed up their workflow, particularly for selecting and moving control points to sculpt surfaces.

See pages 36-38 in the Getting Started guide for more information on customizing the interface.

Instead of a Special View Block on the right side of the ICEM screen, AliasStudio has the *Viewing Panel*, which appears in the top left corner of the perspective window

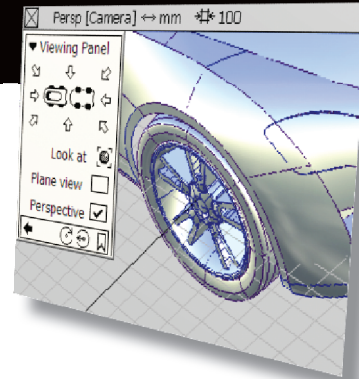

View Planes & Work Planes

AliasStudio doesn't use the concept of a separate work plane and view plane.

In a 3D view, only the XY (ground) plane is shown as a grid. Objects can be placed on this ground plane using grid snap. Otherwise, objects are positioned by snapping them to points on existing geometry, and motion is controlled in the x,y and z directions using the mouse buttons.

This changes when you switch to a 2D orthographic view (with no perspective). You can freely place objects and they are drawn on the plane of the view (similar to setting the work plane the same as the view plane in ICEM). The mouse buttons also switch to a *drawing board* mode (free / horiz / vert) which allows for quick and accurate control of geometry.

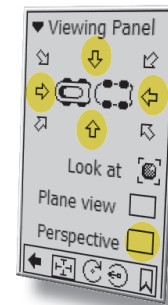
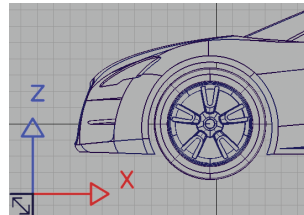
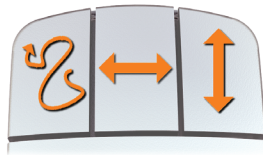

Construction Planes (Workplanes)

To work in an alternative to the default x,y,z plane, use **Construction > Plane** to create a new work plane. You can have as many planes as you like, but you can only set one at a time to be the *Construction Plane*.

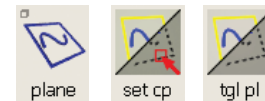

Note: The Preferences > General Preferences *Input* options control how the mouse buttons work in a construction plane.

Mouse mapping for perspective move

On ground plane

Left=X Mid=Y Right=Z

On construction plane

Left=Free Middle=X Right=Y

Constrained Tumble

The **Azimuth/Elevation** and **Twist** icons give you extra control over the tumbling of the view.

Alternatively you can customize the view interaction in the General Preferences option window, Input section.

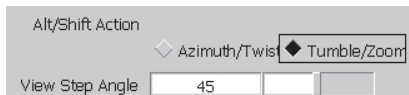

Selecting **Azimuth/Twist** changes the action of the right mouse button. Moving the mouse vertically zooms in and out, moving the mouse horizontally twists. Experiment with the two options to see which feels more familiar.

Compressed View

When Perspective is turned *off*, the **Aspect Ratio** icon is shown. Click on the icon, and then click and drag the mouse to interactively compress the view.

To return the view to equal scaling, a shortcut is to turn perspective on, and then off again in the Viewing Panel.

Alternatively, use the Reset View tool from the View palette.

Additional viewing tools are available on the View palette.

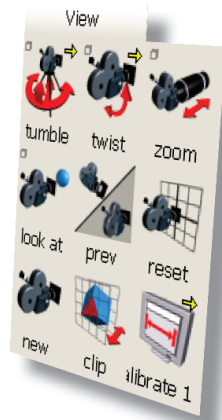

Look At

Equivalent to the ICEM Auto Min Max (F2). If no objects are selected, then the whole model fits into the view. If any objects are selected, they are brought into full view.

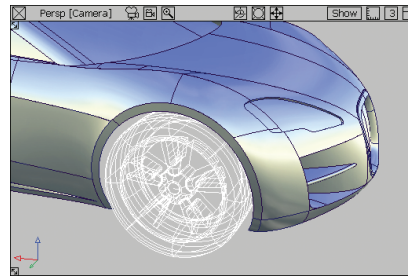

Look at also adjusts the speed of zooming to suit the size of the geometry, and sets the point of interest onto the object.

Point of Interest

The viewing center is called the *Point-of-Interest*. It defaults to the grid origin but can be re-positioned by clicking on a piece of geometry during viewing (Shift + Alt + Mouse Buttons).

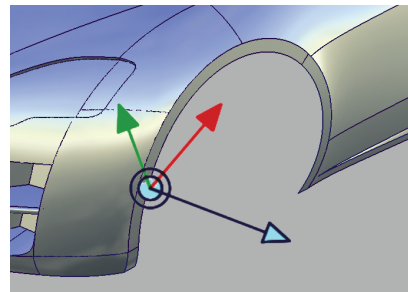

Moving Frame vs. Pivot Points

In ICEM, you have a *moving frame*, which is used to specify a *from* and *to* location when moving objects. Although you can have many stored planes, only one can be used as the moving frame at a time, and it is used globally for any object that needs to be moved or rotated.

AliasStudio works differently. Instead of one general location, each object (surface or curve) has its own individual Pivot Point, which is displayed as a green point when the object is selected. This pivot point defines the starting location used when transforming the object, and must be positioned correctly before choosing a transform tool.

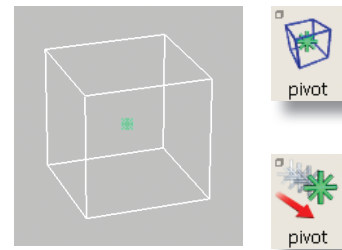

The location of the Pivot Point is set using the **Set Pivot** and **Center Pivot** tools, usually with the snapping tools for accuracy.

When using **Transform > Move**, the pivot point is the *from* location, so you need to make sure it is in the right location before you move the object.

With **Transform > Rotate** the pivot point is the centre of rotation. The axis and amount of rotation is determined by either the choice of mouse button (x,y,z) or by typing in a coordinate value to the prompt line.

Place Tool : Moving via Planes

Transform > Object Placement > Place works in a similar way to the ICEM *moving frame*. You can create two planes, one for the *from* location and one for the *to* location. This is useful for complex positioning, but for most tasks the pivot point system is easier and quicker to use.

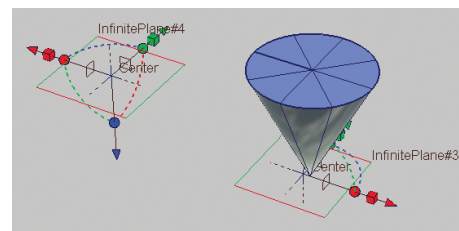
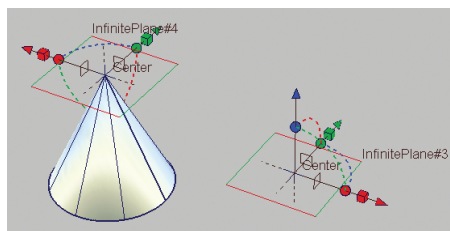
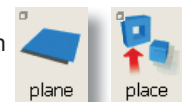

Sculpting NURBS Surfaces

7

Surface Math

Working with Control Points

Move CV Tool

Snapping to Points

Surface Evaluation

Modeling Tips

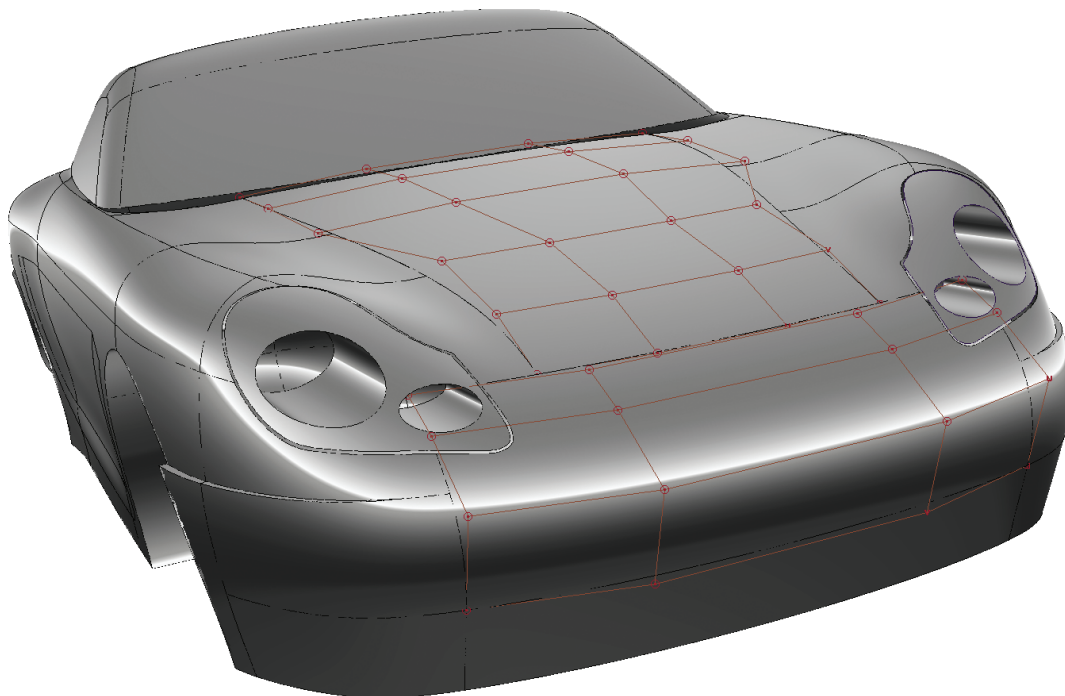

Bezier

ICEMsurf uses Bezier math to construct surface patches and curves. The benefit of Bezier math is that patches are smooth and have no internal continuity breaks – essential for Class A quality surfacing. Bezier is a sub-set of the Non-Uniform Rational B-Spline (NURBS) math used by AliasStudio. This means that all the expertise and experience you have using Bezier surfaces transfers easily to working with NURBS.

AliasStudio uses NURBS in two ways: single-span and multi-span.

NURBS Single-Span

Single-span NURBS are exactly equivalent to Bezier Math. Interaction with the control points results in the same surface shape, and smoothness is guaranteed. The only difference for an ICEM user is in the terminology used.

In ICEM, the order of the patch or curve segment determines the number of control points available to sculpt the surface shape. With AliasStudio, NURBS degree is used in the same way. The relationship between the two is : Degree = order - 1

To show the terminology AliasStudio uses, here is an example of a single-span Degree 3 (order 4) curve and surface.

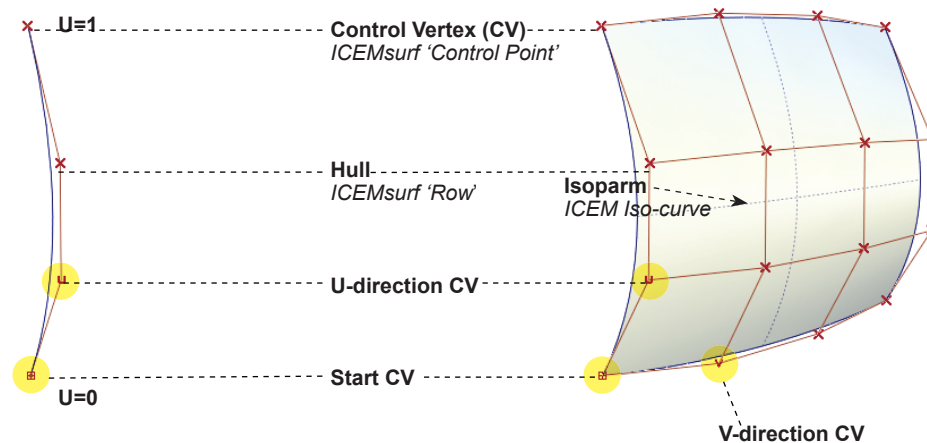

Curve = ICEMsurf 'Curve Segment'

Surface = ICEMsurf 'Patch'

NURBS Multi-Span

Multi-span surfaces are used mostly for quick or concept modeling, where the requirement to create the geometry quickly outweighs the need for surface quality.

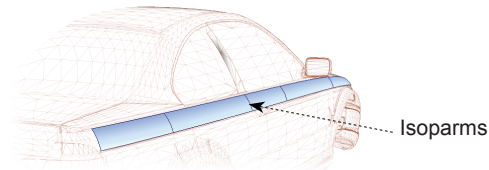

The quality limitations of multi-span curves and surfaces are at the segment boundaries between spans, shown by **isoparms** on a surface and **edit points** on a curve. In these two examples of a degree 3 curve, the first is a single-span curve and has edit points only at each end. The curvature plot is smooth.

The second curve has interior edit points. The internal continuity across these edit points is G2 (curvature), which is fine for general CAD modeling, but may not be good enough for Class A surfacing. The curvature plot clearly shows G3 breaks at the edit point locations. The problem is less exaggerated for higher degree curves and surfaces, and more noticeable for degree 2 geometry.

Single-span Curve

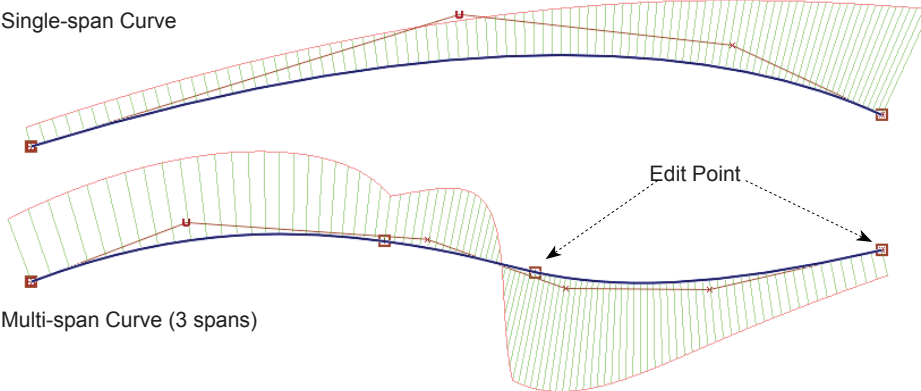

Multi-span Curve (3 spans)

Explicit Control

Many of the tools in AliasStudio have an **Explicit Control** option, which gives you control over the control point layout in a surface. Keeping the spans at 1 ensures that Bezier geometry is always created.

(In some tools there is a Bezier option, which serves the same purpose.)

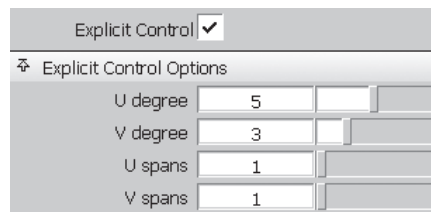

Working with Control Points

The Control Panel on the right hand side of the AliasStudio screen has most of the tools you need to sculpt control points to shape your surfaces. Some of the Control Panel tools always apply to the selected objects, so first use Pick > Object to select your curve or surface.

Change Degree (Order)

Select the curve or surface to be modified and type in the required degree (order -1) in the U and V direction. The change is previewed on the screen. Click in the **Accept** box that appears at the bottom right of the screen to confirm the change.

Displaying Control Points

Use the Control Panel Display section to control the display of the selected objects (use Pick > Object to select the surface(s) or curves for display). Deviation controls the display of the **scandev** icon at the bottom of the control panel.

Iso-Curve Sections and Curvature

Display curvature plots along the Iso-curves of a surface. Use the Curvature tool at the bottom of the Control panel to adjust the display.

Shading and Diagnostics

You can apply a simple color, or use the 'zebra' highlights, curvature or draft analysis of your surfaces. Use the small triangle below the shader icons to access the options for each shading method.

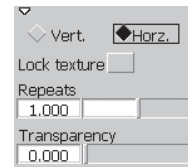

Cross Section Control

Apply x,y,z , radial or plane based sections, and display a curvature plot on each section. Control the curvature sampling and scaling using the Curvature icon at the bottom of the Control Panel.

Tools

Tools for moving CVs and creating deviation and curvature diagnostics. The following pages describe the Move CV tool in detail.

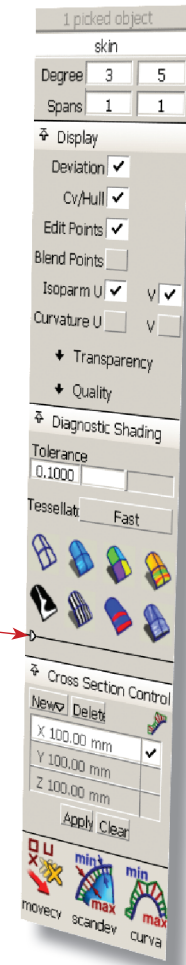

Move CV tool

For quick, coarse movements of CVs, you can use the **Transform** palette tools with *Pick > Hull* and *Pick > CV*. For fine control and accuracy you need the advanced tools available with **Move CV**.

Move CV has similar functionality to the ICEM Control Point window.

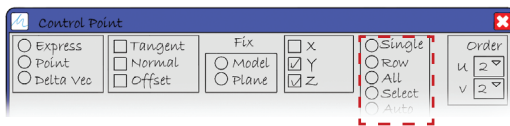
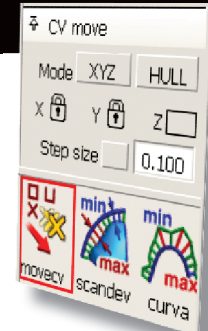

Selecting CVs to Move

The right pop-up Mode menu lets you select single CVs or rows (Hull). When using the Move CV tool, use the Shift key to select more than one CV or Hull.

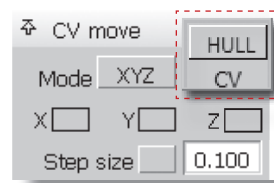

Alternatively use the *Pick > CV* or *Pick > Hull* tool from the Pick palette to drag-select many CVs before selecting the Move CV tool.

ICEM 'All'



The ICEM *All* function is not available in Move CV: instead use the **Transform > Modify > Proportional Mod** tool.

The Falloff value is normally set to 0, 0.5 or 1 and is similar to the 'law' in ICEM which governs how CVs follow the main CV. The *preceding* and *succeeding* settings determine how many CVs follow the main one selected.

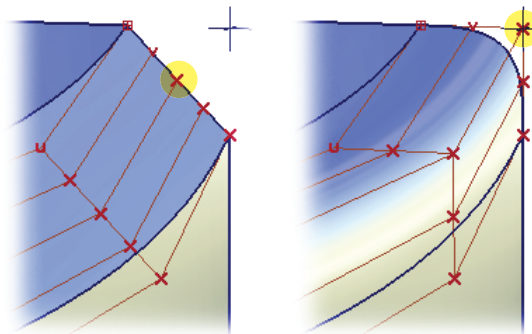
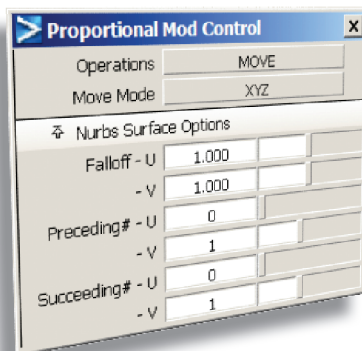

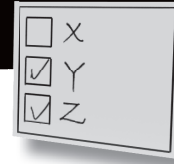

The left pop-up Mode menu covers the functionality of both the XYZ and the Tangent, Offset and Normal options in ICEM.

XYZ

When working in a 3D view, the mouse buttons constrain motion in the x, y and z directions. (*Note: In an orthographic view, the mouse buttons switch to a drawing board motion of free/horizontal/vertical.*)



The *lock* options are a secondary tool: use them to prevent a CV moving in one direction in case the wrong mouse button is used.



The *Step Size* setting is used in the same way as *Mousewarp* and *Delta* in ICEM. Use it to specify the increments using the keyboard arrows, and to adjust the influence of the mouse movements to make very fine adjustments.

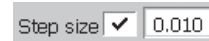

NUV (ICEM Offset)

Each CV selected moves along its own normal direction from the surface. The NUV function uses the three mouse buttons to move the CVs normal to the surface, or in the U or V direction.



Slide (ICEM Tangent)

The slide function moves CVs along hull lines. Arrows appear on the chosen CVs, allowing you to choose which hull line to use as the guide.

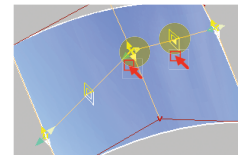

The arrows on the hull can be used to skew the CVs.

Proj (ICEM Normal)

CVs move in the direction of a selected hull or vector. Use the Parallel option to maintain the CV offset.

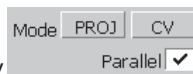

Use this tool where you would use the ICEM 'Normal' or the 'Delta' Vector tools.

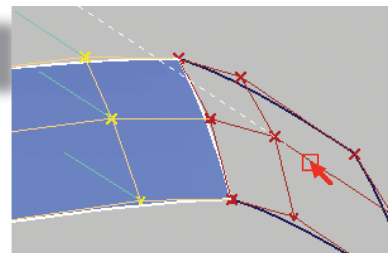

Snapping to points

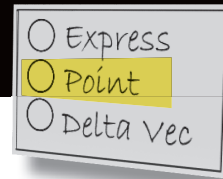

In the ICEM Control Point window, the Point option opens a Selection window to specify around 20 different types of points : end points, corners, edges, etc.

Alias has a simpler approach, where there are only three things you can snap to — grids, curves and points — which are specified by holding down a combination of the Ctrl and Alt keys when clicking on the desired geometry.



Point Snap (Ctrl) :

In AliasStudio, a *point* refers to one of the recognized control points, and they must be made visible using the Display section of the Control Panel.

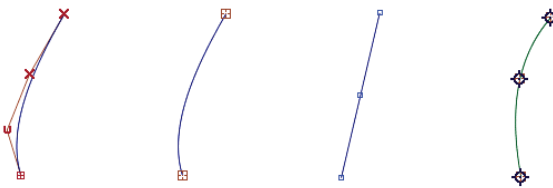

CV Edit Point Key Point Blend Point

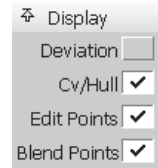

Curve Snap & General Points (Ctrl + Alt)

The curve snap attaches to any curve, line, arc, surface edge, iso-curve or face edge.

Corners can be found by clicking on an edge, holding down the mouse button and dragging the cursor until it reaches the blue cross, which turns yellow to indicate that it has been accurately snapped to.

Mid-Points and sub-divisions can be found by changing the settings in the Curve Snap Options, next to the snapping icons (top right).

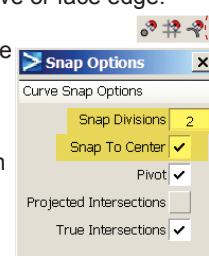
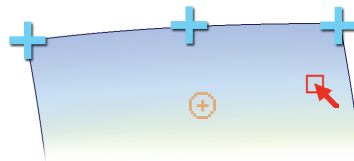

Grid Snap (Alt)

Mostly used to snap control points onto the center line grids.

Cross Sections and Curvature

The pre-set x, y and z sections can be applied to selected geometry, and modified by double-clicking to open the option window. Click on the curvature icon to display a curvature plot along the sections, which automatically update as you model.

Use *New* to create additional section ranges, and *Clear* to control the display of the sections.

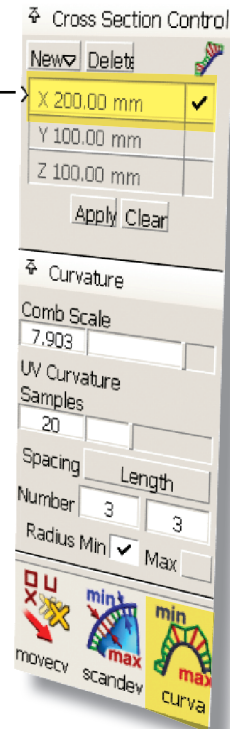
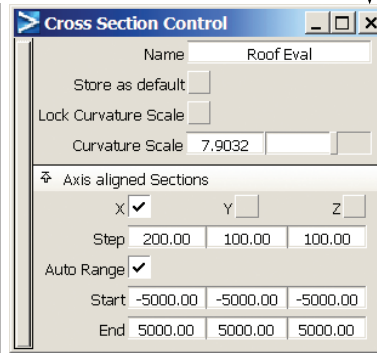
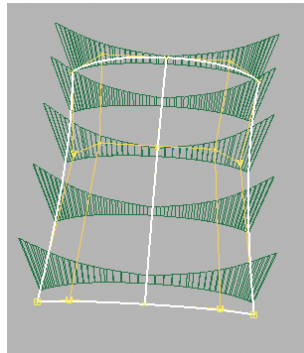

Reflection Lines (Iso-Angle)

A more accurate evaluation than the zebra stripe shading is provided by the **Iso-Angle** tool. This shows you the line of zero angle between the surface normals and an infinite 'light source direction'.

This is found on the Evaluation Palette where you will find additional advanced tools. Double-click to open the option window to set up the display.

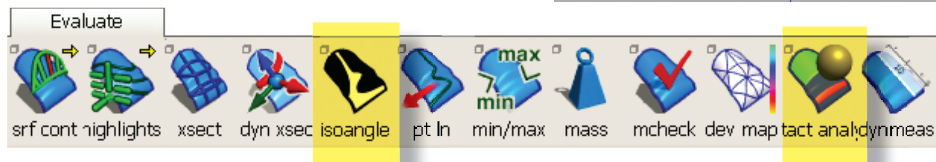
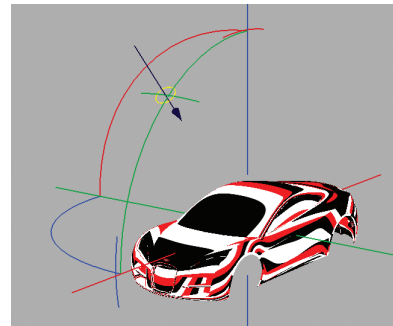

Controls on/off

Turning on the display of control points is something you will do hundreds of times a day, and so it is particularly useful to set up a hot key.

To set this up, use **Preferences > Interface > Hotkeys/menus**.

Near the bottom of the option window, there is a **Special... Display Functions** section. This lists settings available in the Object Display > Control window.

Most experienced users set up the two options illustrated (you can choose any hot key you like, F3 and F4 are just examples).

Alternatively, set up the marking menu with the **Object Display > Control** settings.

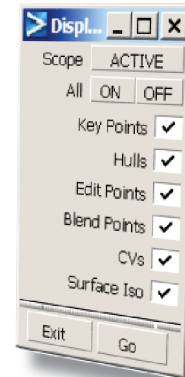
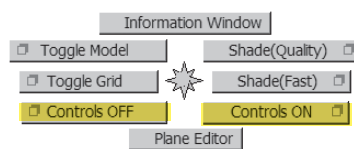
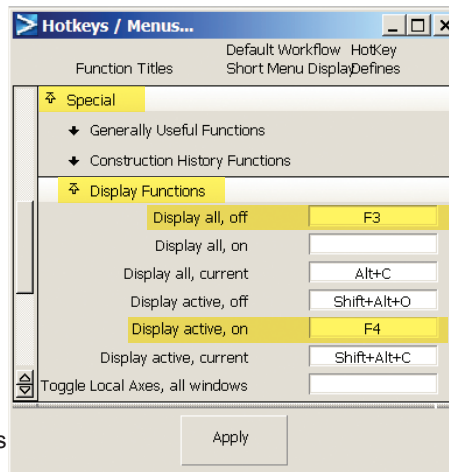

Pick Walk

If you have one CV selected, or one Hull, the *pick walk* lets you step along to the next CV or Hull without leaving the tool you are using. Hold down the Ctrl key and use the keyboard arrow keys.

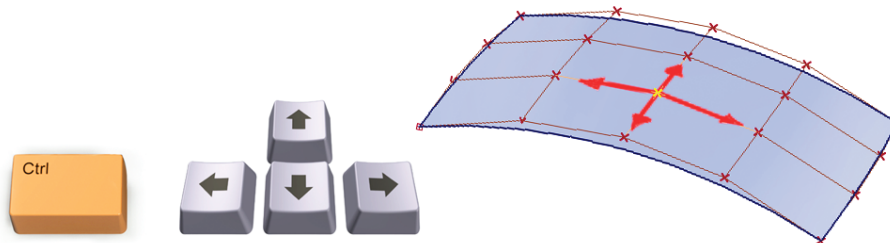

Faces, Trims, & Curves-on-Surface

Cutting Surfaces

Curves-on-Surface

Projecting & Intersecting

Faces and Trims

Workflows

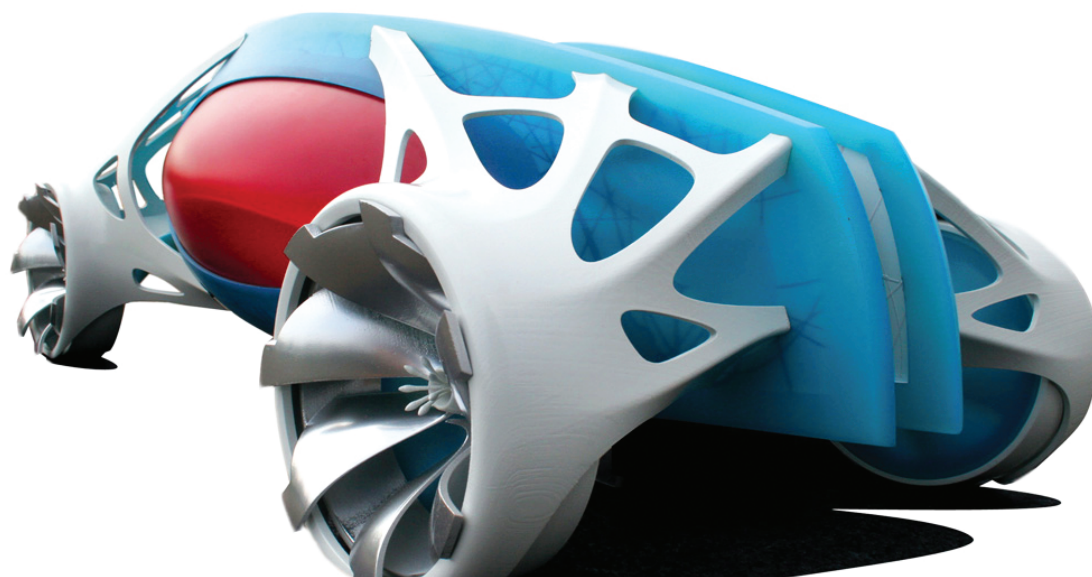

Cutting surfaces

The ways ICEMsurf and AliasStudio cut surfaces have two significant differences. First, the terminology used is different and potentially confusing. Second, AliasStudio has the concept of a Curve-on-Surface, which has no equivalent in ICEMsurf.

Terminology

In AliasStudio, the functions available for modifying surface boundaries are the same as in ICEMsurf, but the terminology is different:

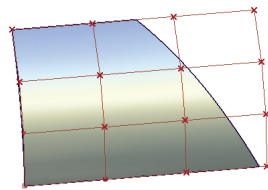

Trim

ICEMsurf: Face

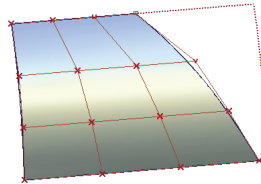

Trim Convert

ICEMsurf: Trim

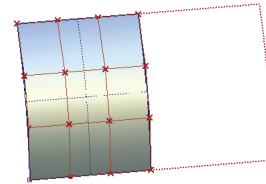

Detach

ICEMsurf: Trim to Iso-curve

Curve-on-Surface

A Curve-on-Surface is different from a normal NURBS or Bezier curve used for modeling and is a fundamental part of the trimming workflow in AliasStudio. A regular curve is defined in the x,y,z modeling space, and is free to move in any direction. A CoS is defined in the UV parameter space of the surface it lies on, and cannot move away from that surface. A CoS also has only Edit Points, no CVs.

In AliasStudio, the only way to trim (face) a surface is to have a Curve-on-Surface (CoS) defining the boundaries of the trim regions. Curves-on-Surface are also important in surfacing operations on the edges of trimmed surfaces. They provide better anchoring of CVs and blend points when attaching to the edges of trimmed surfaces.

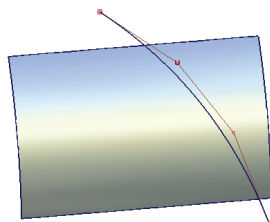

A curve is projected onto a surface...

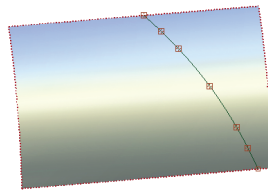

A Curve-on-Surface is created... (in ICEMsurf this would be a Bezier curve)

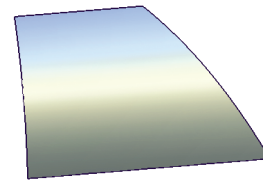

...which is used to trim the surface.

CoS and Construction History

The definition of the CoS is with respect to the surface it lies on; hence the two are linked completely. Any change to the surface will therefore be automatically reflected in a change to the CoS.

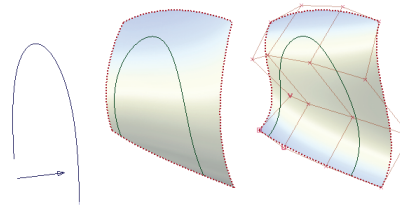

There is also a Construction History relationship between a projecting curve and the resultant CoS. Any changes to the projecting curve will automatically update the CoS. Similarly, a CoS at the intersection between two surfaces will update if the surfaces are modified. (A CoS with history is displayed in green; one that no longer has history, in blue).

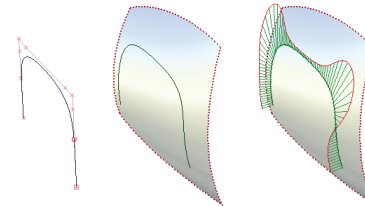

These two characteristics, combined with the use of real-time diagnostics, make working with CoS very interactive and efficient.

Working with Curves-on-Surface

A curve-on-surface has its own selection tool, **Pick > Object Type > Curve on Surface**. Use this to select and delete CoS that are no longer required. (A surface with a CoS on it is displayed with dotted edges.)

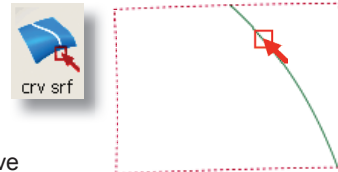

If a CoS or a trimmed edge is converted to a normal curve (using Curve Edit > Create > Duplicate Curve), it typically has many spans. You can rebuild it to Bezier (single-span) using the control panel, and then check it using the deviation tools on the *Locators* palette.



The traditional workflow in AliasStudio has two steps: creating the CoS and then trimming the surface. The following pages describe the *Surface Edit* palette tools used for each step.

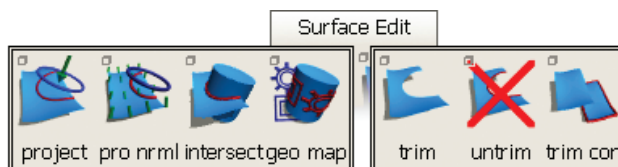

Step 1: Creating Curves on Surface (CoS)



Projecting a Curve along a Surface Normal

This method works best when the curve is close to the surface. To use it accurately, you should adjust the tolerance values in the option window.

Tolerance

The smaller the value, the more accurate the projection, but the longer the calculation time required.

Curve data factor

The default is 1, which is sufficient for most surfaces. Larger values increase calculation time. (Only increase the value for very simple surfaces.)

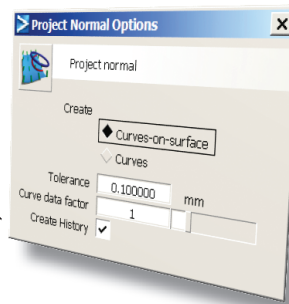

Projecting a Curve along a Vector

Any curve, (edge or isoparm) can be projected onto a surface to create a CoS. There are two ways to select the direction of projection:

Using a vector — First create a vector using *Construction > Vector*, then select the vector when prompted by the Project tool.

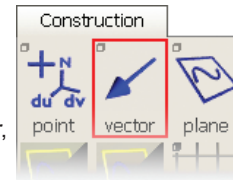

Using the current view direction — typically you use an orthographic view (with perspective turned off) to get an accurate projection and predictable result.



Surface-Surface Intersection

The *Intersect* tool calculates the intersection line between the selected surfaces, and creates a CoS on each surface. This can be used to trim the surfaces to the intersection.



The *Locators > Curve Curvature* tool can be used on the CoS to analyze the surface-surface intersection (SSI). It dynamically updates as the surfaces are modified.

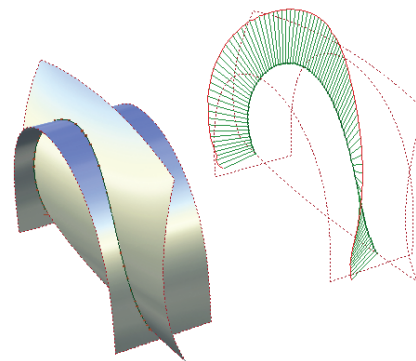

Trim (ICEMsurf: Face)



The trim tool only works on surfaces that have one or more CoS. You are prompted to select the surface *twice*: first to choose the surface, and then to select the region(s) of the surface you want to keep.

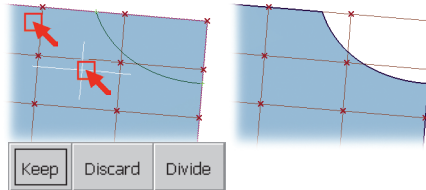

There are no tolerances displayed during the trim operation; instead, the tool uses the settings in the Trim section of *Preferences > Construction Tolerances*. You will typically tighten these tolerances as shown. Tolerances are described in more detail in the next chapter.

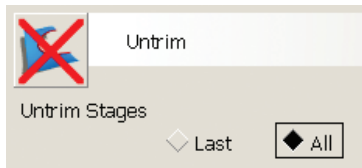
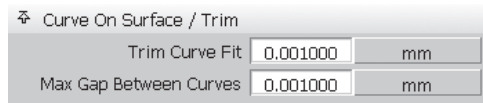

Open the **UnTrim** option window to choose untrimming step-by-step for multiple trims, or all trims at once. Don't forget to pick and delete the old curve-on-surface if you no longer need it.

Trim Convert (ICEMsurf: Trim)

In AliasStudio you first need to Trim the surface, and only then can you use the **Trim Convert** tool to re-build the surface with a natural edge.

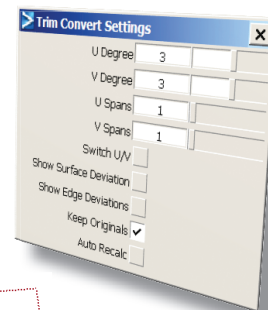
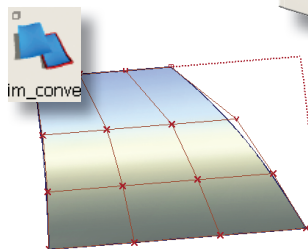
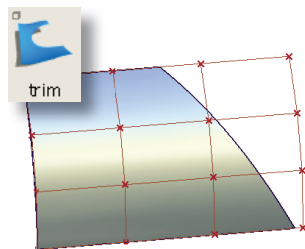

Trimming without Projecting First

To avoid the two-stage process, the *3D Trimming* option in the **Trim** tool allows a workflow similar to that used in ICEM. The option allows you to select the surface, the curve and the region to keep in one operation.

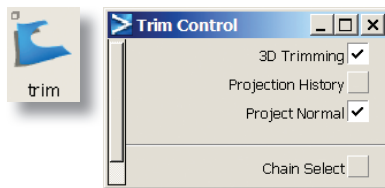

Its success depends on choosing the correct view (to determine the projection direction) or using the Project Normal option.

Trim to an Iso-Curve

Splitting a surface at an isoparm doesn't require the use of CoS. Extra isoparms (iso-curves) can be shown using the Object Edit > Patch Precision tool. Use Object Edit > Detach and click on an isoparm in the direction you want to split the curve. Use the Alt and Ctrl keys to snap exactly on isoparms and mid-points.

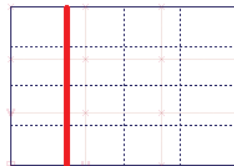
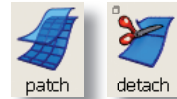

Ctrl: Snap to isoparms

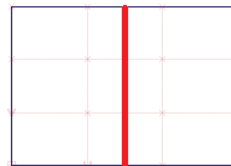

Alt: Snap to 0.5 parameter (mid-point)

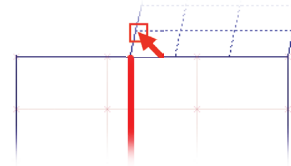

Ctrl + Alt: Snap to adjacent surfaces

Creating Curves instead of CoS

The **Project** tool has the option of creating a standard curve instead of a curve-on-surface. Setting **Match Original** to *on* creates the projected curve with the same number of CVs as the curve being projected.

With **Match Original** *off*, the curve is more accurate, but has more spans.

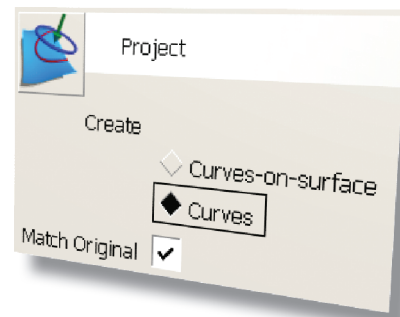

Matching surfaces

G0, G1, G2

Align

Modeling Tolerances

Construction History

Measuring Continuity





The equivalent of the ICEM Match tool is **Object Edit > Align**. This tool creates a G0, G1 or G2 relationship between two surfaces (or two curves) and maintains that relationship as CVs are moved.

Alignment Type : Edge

Open the Align option window to choose the continuity level, skewed or aligned edges, and options for part alignment and blending extra CV rows.

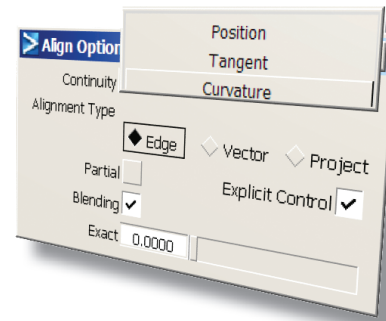

Using the *Edge* option when aligning natural surface edges allows free movement of the CVs.

Follow the prompts to first select the edge of the surface to be modified and then the reference edge to be matched to.

Manipulator arrows appear on the Hulls. Use these to interactively adjust the CVs while maintaining continuity.

1. Select **input** (connection edge)

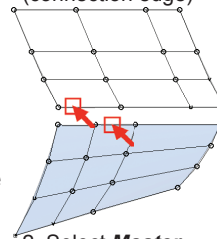

2. Select **Master** (reference edge)

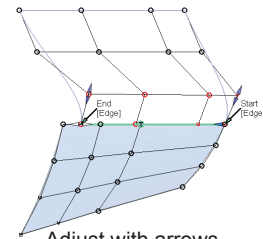

Adjust with arrows.

Exact Slider

In this example, G2 (curvature) continuity has been specified.

If **Exact = 0**, there is minimal movement of the CVs.

If **Exact = 1**, the G0 CVs are exactly matched to the CV locations on the master surface, and the G1 and G2 CVs adapt to match the length ratio of the master surface tangents.

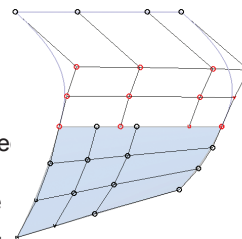

Exact = 0

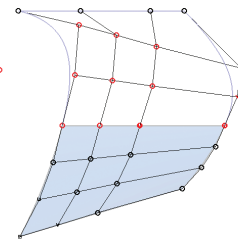

Exact = 1

When matching surface edges the CVs on both surfaces naturally align. However, when matching to the interior of a surface, or to a trimmed edge, the CV layout may be mismatched, and so a different method is required. The Vector and Project options provide vector-based control over the alignment direction of CVs.

Vector Options

A vector can be specified as being in the X,Y, Z axis directions, in the view direction, or the surface normal direction.

Alternatively, you can create a vector entity using the Construction palette, and rename it using Windows > Object Lister. The vector can then be selected using the *Picked Vector* option.

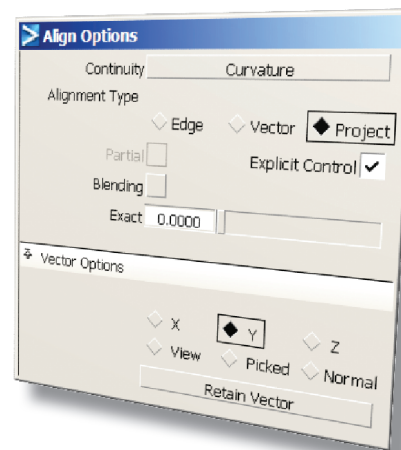

Alignment Type : Project

The *Project* option allows you to align a natural edge to the interior of a surface. How the CVs are moved is specified by the vector you select. A curve-on-surface is created on the master surface along the aligned edge.

In this example, the CVs on the wheel arch surface have moved in the **Y** direction, to meet and align with the surface.

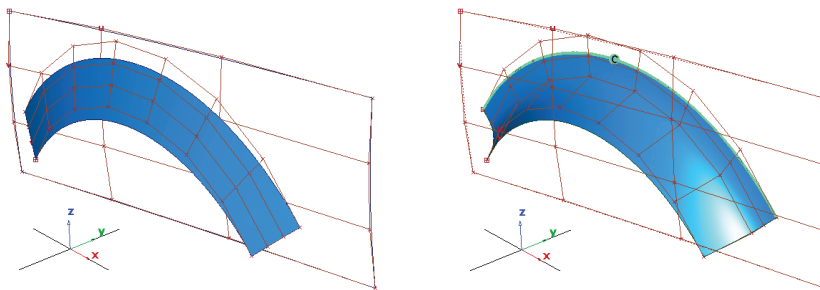

Alignment Type : Vector

This option only applies when aligning surface edges. It allows the tangent and curvature CV rows to move along one direction only (specified by a vector). The Align tool attempts the best alignment given this constraint.

It is essential to know how accurately the two surfaces have been matched, and to control the level of accuracy so that it is appropriate to the design phase.

AliasStudio Construction Tolerances

AliasStudio differs from ICEM in that it has one master set of tolerances that it uses for all tools. These are set using **Preferences > Construction Options**, which opens the construction options window:

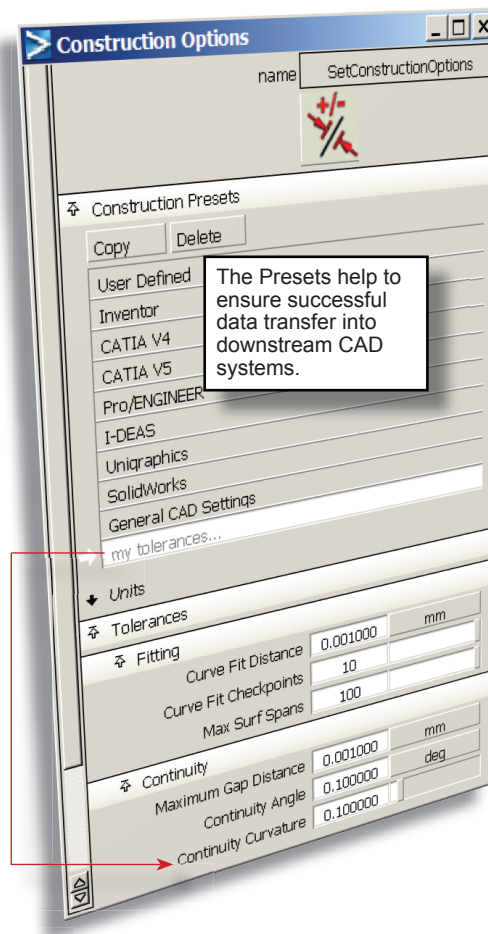

Construction Presets

The construction Presets are useful as a starting point, but for Class A surfacing you typically want to define your own tolerances.

Choose one (CATIA V5 is a good choice) and click **Copy** to create your own, customizable set. You can rename the set, and have as many different sets as you need.

Units

The modeling units should default to mm; use this section to check or modify the units.

Tolerances: Fitting

Checkpoints are how many times an edge is checked for tolerance. Increasing this value increases the accuracy of checking, but can slow down the system.

Tolerances: Continuity

The three settings are for G0, G1 and G2 continuity measurements.

Curvature is measured as

$$\text{Curvature Deviation} = \frac{(\text{Radius1} - \text{Radius2})}{\text{Radius1} + \text{Radius2}}$$

Tolerances Workflow

You must select your tolerance settings in the Construction Options window *before* you start to model.

AliasStudio will then use these values as a goal to align two surfaces. If it can't achieve the required tolerance with the number of CVs available, it may increase the degree or the number of spans.

Explicit Control

To avoid this and maintain Bezier (single-span) geometry, you can use the Explicit Control option to specify the number of CVs.

If you cannot achieve the tolerance you need, then it is your choice to increase the degree, or re-design your control point layouts to solve the problem.

Tolerance Display

If the Continuity Check option in the Align tool is selected, the tolerances are shown on the geometry at the aligned edge.

Yellow (selected) or red (unselected) indicates that the continuity achieved is not within the tolerances set in the Construction Options, and the values are displayed.

Green indicates that the continuity is achieved, but the tolerance values are no longer displayed. If you prefer to always see the tolerances, set very high tolerance values in the Construction Options window, and use your own judgement to assess whether they are successful.

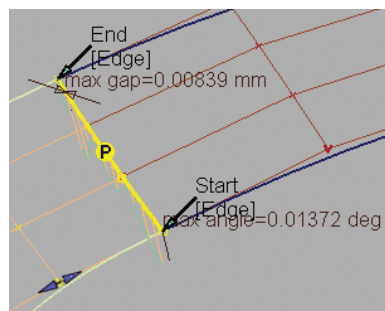
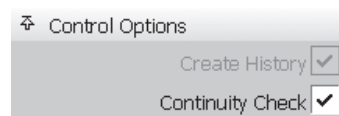
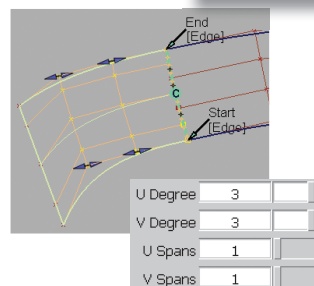
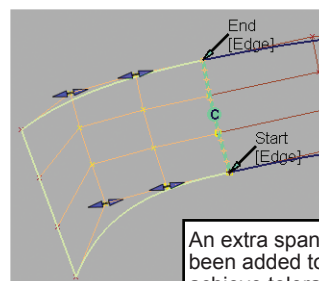

Construction history

Construction history is the saved information about how an object or an action was created. When you edit the construction history the object or action will automatically update.

A curve or surface with Construction History is displayed in dark green wireframe color, indicating that the history can be re-activated at any time.

With the Align tool, the Construction History works in two ways:

Master/Input CV Alignment

When CVs are selected and moved on the master surface, CVs on the input surface automatically update to maintain continuity.

When CVs are selected and moved on the input surface, they can only be moved to *legal* positions, where the continuity will be maintained. CVs moved to *illegal* positions will *jump back* to a correct position when you release the mouse button.

To delete the construction history use **Delete > Construction History**. The surface reverts to dark blue and the CVs can be moved independently.

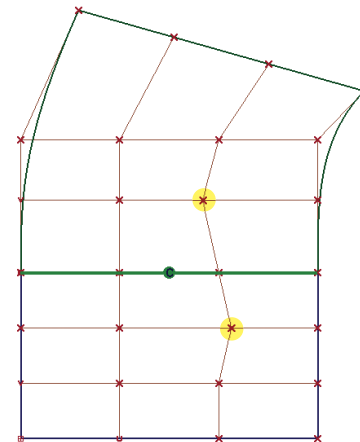
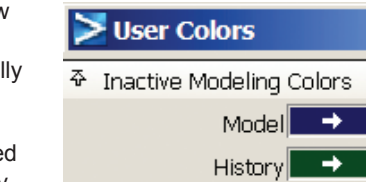

Re-Activating the Option Window

The option window can be re-opened at any time and the options modified, for example, to change the Continuity from Tangent to Curvature. Use the **Object Edit > Query Edit** tool, click on the secondary surface with the left mouse button and the option window re-opens. Changes made now affect the secondary surface.



To update the surface, choose the Auto Recalc option, or click on the Recalc button at the bottom of the option window.

To *undo* an alignment, click on the **Revert** button at the bottom of the Align Options window

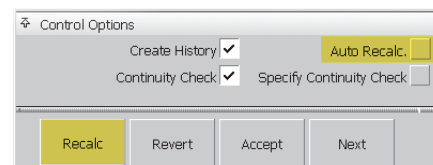

The tolerance display used by the Align tool is a subset of the functionality of the **Surface Continuity** tool found on the Evaluate Palette. All of the functions and workflows described here equally apply to the embedded continuity check in the Align tool.



Surface Continuity Locator

The Surface Continuity tool checks the boundary between two surfaces and creates a *Locator* to display the G0, G1 and G2 accuracy. A Locator is a special entity used to check and display information, and it has its own *Pick* and *Delete* tools. (Other locators can be found on the Locators palette.)



There are three ways to select the display options for Surface Continuity:

1. Double-click on the icon to open the option window before selecting the edge.
2. Use Windows > Information > Information Window to display and modify the settings after selecting the edge, when the locator is selected.
3. Use the mouse buttons to interactively adjust the settings as described in the prompt line, shown below:

[L: toggle boundary, scale comb]



Click on the join between two surface patches. The locator is shown.

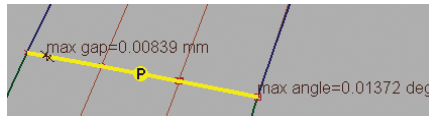

[M: toggle comb, adjust sampling]



A single click with the middle mouse button shows the comb; clicking and dragging adjusts the sampling.

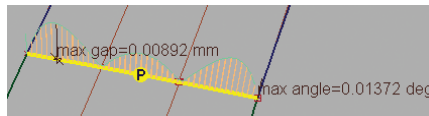

[R: info]



For detailed information at a particular location, use the right mouse button.

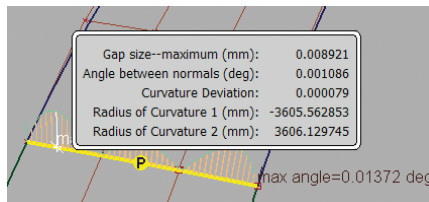

Use Delete > Locators to remove the locator.

Building with Curves and Surfaces

Creating Curves

Blending Curves

Accurate Arcs

Useful Curve & Surface Tools

Primary Surface Tools

Transition Surfaces

Advanced Blending

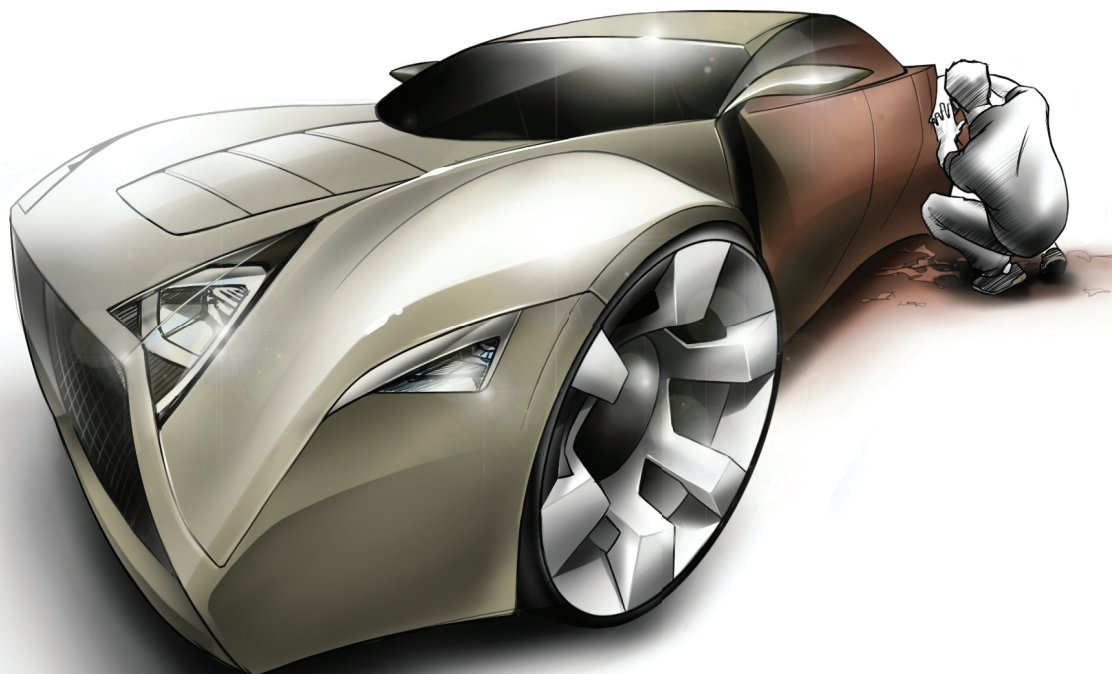

New Curve by Edit Points

The **New Curve by Edit Points** tool is the most common way to start a curve. Simply click a start and end point on the screen to create a single-span (Bezier) curve.

To create a symmetrical curve for example, use **Grid Snap** to place the ends equally across the centre-line. Open the option window to select the degree (order) of the curve.

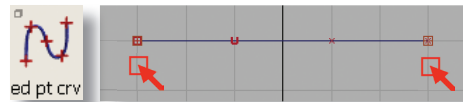

There is no functionality in AliasStudio to force the CVs to be symmetrical. You need to maintain symmetry by using **Pick > CV** and the mouse constraints carefully.



Modify the **Degree** in the Control Panel to change the number of CVs. Keep *Spans* set to 1 for a Bezier curve.

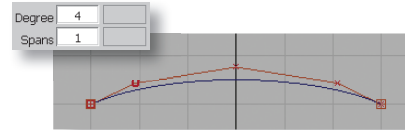

Displaying Curvature

Use the *Locators > Curve Curvature* tool to display a comb on the curve to evaluate it as you move CVs.

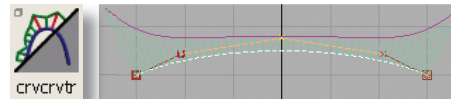

Follow the prompts to select the curve and use the mouse buttons to adjust the display.



Use **Windows > Information Window** to modify the curvature display.

Use **Delete > Delete All Locators** to remove the display.

Blending Curves



The **Object Edit > Align** tool can be used to blend any curve into a surface (or another curve). If the curve isn't aligned to an edge or an isoparm, project a curve-on-surface to use as a reference to align to. Alternatively you can use Blend Curves, which offer automatic alignment and Associativity.

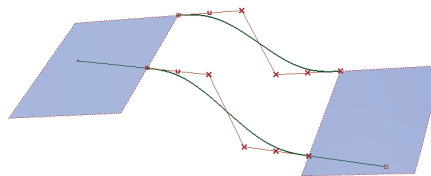

Blend Curve Toolbox

Blend Curves attach to surfaces and automatically align with G2 continuity. The curves are normal NURBS curves, typically single-span degree 5, but are manipulated using Blend Points, not CVs. Blend Curves have construction history, and maintain their connection to the surface while the surface is modified.

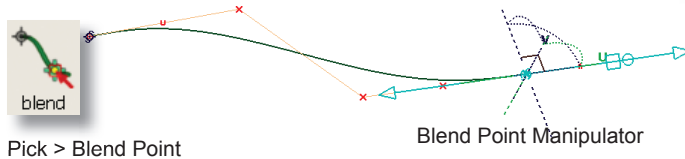
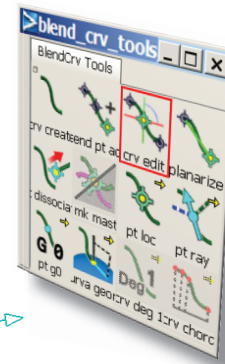

Pick > Blend Point

Blend Point Manipulator

Blend Curve Tips

See the chapter on *Creating and Fitting Curves* in the **Technical Surfacing** PDF for a full explanation of Blend Curves.

By default, CVs aren't displayed on a Blend Curve. Use **Object Display > Control** to change the default so that CVs are always displayed, or just use the Control Panel to display and monitor CV positions.

Use the *Auto Align at Surface Corners* option in the **Crv create** option box to get good default alignment results

Because Blend Curves are associated with the surface, you need to specify which surface to attach them to. If you select a joint edge, the standard pick chooser appears, with a 'black finger' icon. You need to keep the mouse button pressed down, and drag the cursor to the black finger until it highlights. Keep holding the mouse button down and then drag along the edge to your chosen location.

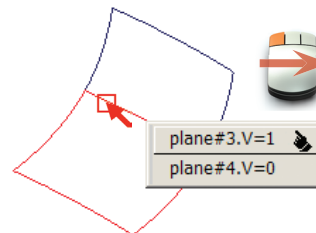

Keypoint Curves

Keypoint Curves are CAD-like drafting curves, creating accurate geometric shapes — in particular, exact arcs and circles. First create the curve in the modeling window. Then, with the curve selected, use Windows > Information > Information Window to type in the dimensions required.

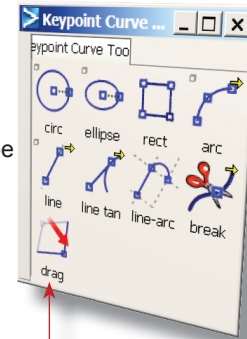
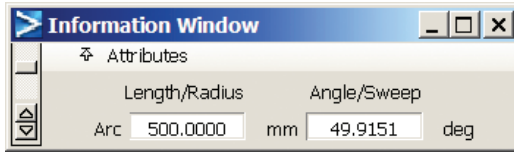

To interactively modify keypoint curves, use the Drag Keypoints tool in the Keypoint curve toolbox.

Rational Flags

This is an option set in the Preferences > Construction Options window and applies to all surfaces of revolution, and to the Circle Primitive (see below).

Non-Rational geometry gives each CV an equal *weighting* of 1. This is the preferred option for modeling, but it has the disadvantage of not creating exact circles and arcs.

Rational geometry allows different weighting on CVs, which is used to create an exact arc.



Curves > Primitives > Circle

With the circle tool, the result you get depends on your choice of Rational Flag, but also on your choice of Periodic geometry set in the Circle tool option window.

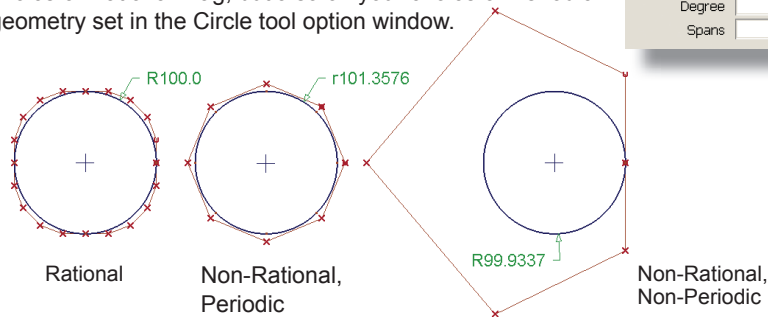
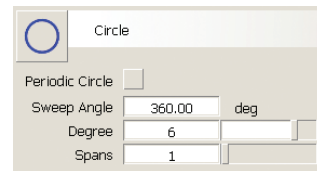

Curves Palette

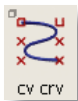

Create Curve by CVs has a *Progressive Degree* option that automatically increases the degree of the curve as you place CV points, up to the value set in the option box.

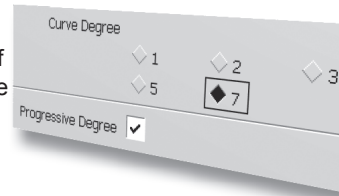

Curve Edit Palette



Use **Duplicate Curve** to create a curve from an isoparm, surface edge, trim edge or curve-on-surface.



Use **Curve Rebuild** (Uniform Knots option) if you have many curves to rebuild. (It's quicker than doing them one-by-one using the Control Panel.)



Curve Planarize flattens a curve onto a construction plane, or to the closest fit.



Curve Section is used to trim curves.



The **Curve Fillet** tool creates the arc curve and trims back the two curves. The radius can be modified using the Information Window.

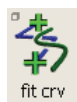

Fit Curve uses two algorithms (Hull Fit and Least Squares) to match a curve to raw data.

Object Edit Palette



The **Symmetry Align** tool forces a curve or surface to stay tangent across a center-line. It works in conjunction with Layers – see the last chapter.



Curve Stretch provides manipulators to modify the curve while maintaining the CV layout.



The **Extend** tool extrapolates a curve or surface to *grow* or *shrink* it without changing the shape.

Surface Edit Palette



Set the *Max Spans Factor* to zero to match the CV layout in the offset curve or surface



Use **Surface Rebuild** (Uniform Knots option) if you have many surfaces to rebuild at once.



Tools for unifying and flipping surface normals.

AliasStudio doesn't distinguish between Patch and Surface tools, even though some tools are limited to creating only a single patch (square, rail, skin) and others will create multiple surfaces if they are built from multiple curves or edges.

The icon colors indicate the function of the tool: Blue icons are the primary surfacing tools for creating the slab surfaces of the design. Green represents a Transition or Detailing surface tool.



Surface from 4 Points

 A quick way to get a starting surface is to use a primitive **Plane** to create a degree 3 (order 4) patch.

 The only tool that creates a surface from corner points is **Square**. You need to specify four points, and these can be placed freely on a work plane, curve snapped (Ctrl + Alt) to raw or scan data, or snapped to existing geometry.

 The Surface Edit > **Fit Scan** tool tries to match the square patch to scan lines.

 The **Point Cloud** palette has tools for creating surfaces on raw data.

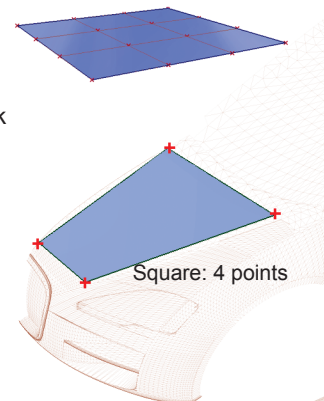

Surface from Curves

 The **Skin** tool creates a simple straight-line surface between two chosen curves, or a multi-span smooth surface through multiple curves (use the Shift key to select more than 2 curves)

 The **Square** tool requires four curves, and they must be coincident (touching) at the corners.

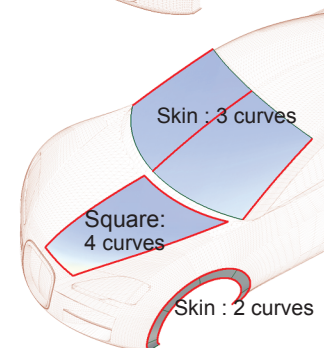

Flange Surfaces



The **Multi-Surface Draft** tool creates a flange surface along an edge, or a chain of edges. Use *Explicit Control* or the *Bezier* option to control the surface quality.



The **Draft/Flange** tool provides a similar function, from curves or surface edges. It can create surfaces on both sides of the curve, either as a pair, or as a single surface.

Profile Surfaces



As a **monorail** (with 1 rail curve and 1 generation curve) the two curves don't need to be touching.



In **Birail** mode (2 rails and 1 or many generation curves) the curves must be touching at the corners. The inputs can only be single curves, edges or iso-curves, and the tool can only create a single surface patch.

Surfaces of Revolution



The **Revolve** tool creates a surface of revolution from one or more curves. The center of the revolve is either the global x,y,z axes, or the object's local pivot point.



cylinder

sphere

torus

cone

Standard revolved shapes can be found on the Surfaces > **Primitives**

menu. They are multi-span surfaces, and the cone and cylinder are grouped surfaces.

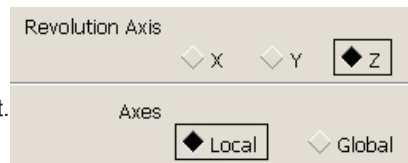
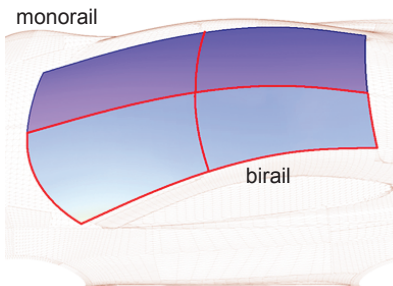
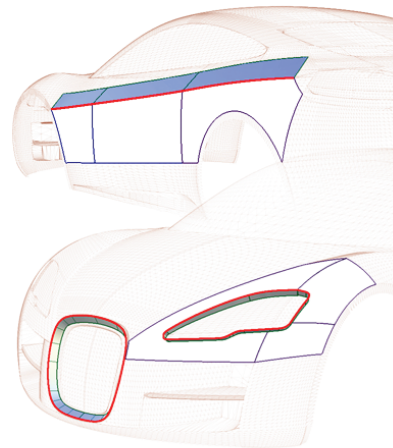



The blending surface tools are designed to work with Construction History. The blend surfaces update as you sculpt the slab surfaces, allowing a quick exploration of forms, while giving a finished appearance useful for design review.

Using the default settings, the tools may create multi-span surfaces not suitable for Class A modeling. However, the option window provides Explicit Control, which you can use to control the surface quality.

Freeform Blend

Freeform blend creates a surface that bridges the gap between two other surfaces (or groups of surfaces), and matches continuity at the edges. The *chain select* option lets you select multiple edges with one click.

In its default mode, it typically creates heavily parameterized surfaces, but if you work with the Explicit Control options you can get good results for concept modeling.

Use the Flow Control options to define the end conditions.

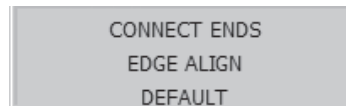

Profile Blend

The Profile Blend tool uses additional profile curves to further control the character of the blend surface.

Ball Corner

The Ball Corner tool is designed for the iterative stages of a design, when you may need to finish off a model quickly for a presentation.

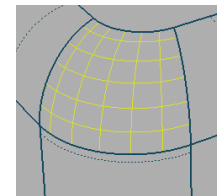
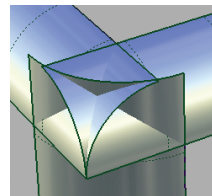
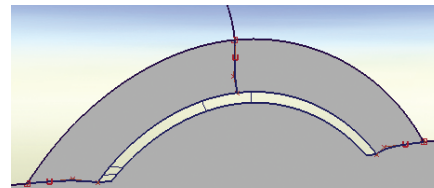
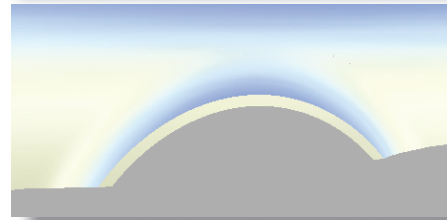
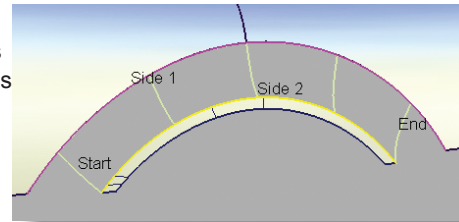



Surface Fillet

The tool will build a fillet surface, and then cut back (Face) the slab surfaces in one operation. It is not necessary to find the theoretical intersection of the slab surfaces before using the Surface Fillet tool (though you may choose to do so for quality purposes).

Construction history means that you can build the fillet surface and then modify any of the settings in the option window, and the fillet surface will update (hit the Recalc button or set Auto-Recalc in the options)

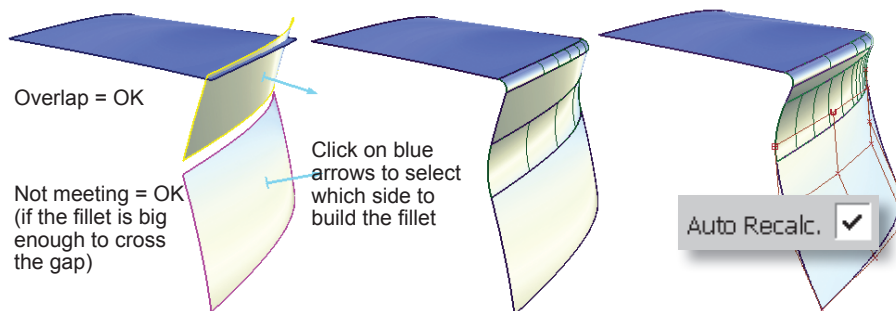

Quality & Profile Options

The *Construction Type* and *Section Type* options provide the full range of fillet profiles.

Use the Flow Control options with Explicit Control and Bezier settings to adjust the CV layout.

Tip: With Variable radius, use the *Shift* key to add or remove additional radius values by clicking on the orange radius values along the edge.

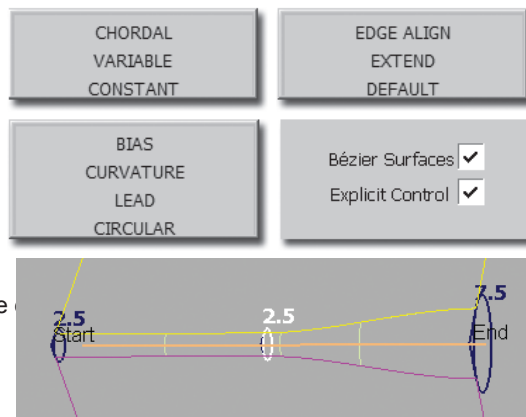



Continuity

The Rail and Square tools have the option to specify a continuity relationship with the surface edges they are built from.

The Position, Tangent and Curvature are standard G0, G1 and G2 relationships. The other continuity options are explained below :

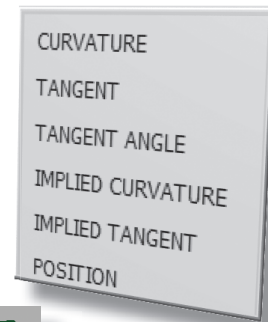

Tangent Angle

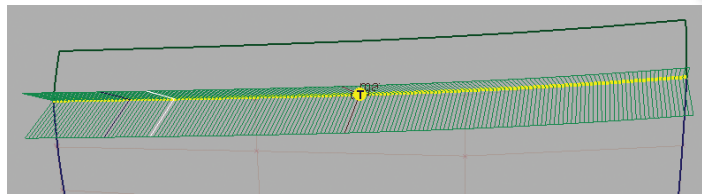

Position: angle may vary

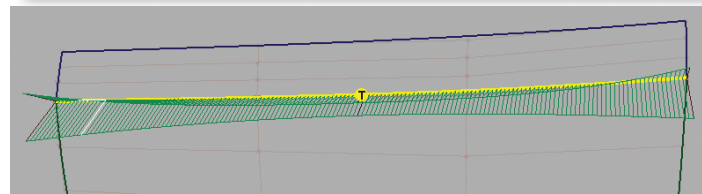

Tangent Angle: consistent angle

Implied Tangent / Curvature

Use on the center-line edge of a symmetrical half to ensure tangency between the mirrored surfaces. Implied Tangent gives better results than Implied Curvature.

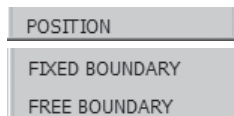
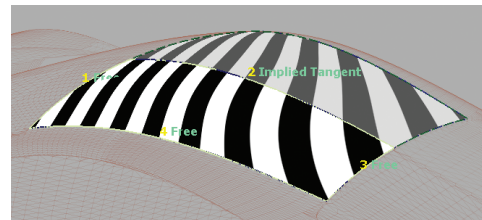

Square: Fixed Boundary / Free Boundary (G0)

The Fixed option holds continuity strongly. Free (and Position in the Rail tool) are more relaxed, and let continuity fail on this edge if it helps to create better results on other edges.

Rebuild

The Rebuild 'ticks' can help to improve the parameterization of edges, particularly when building from trimmed edges, or when opposite edges have different parameterization. Use with Explicit Control to get the best CV layout.

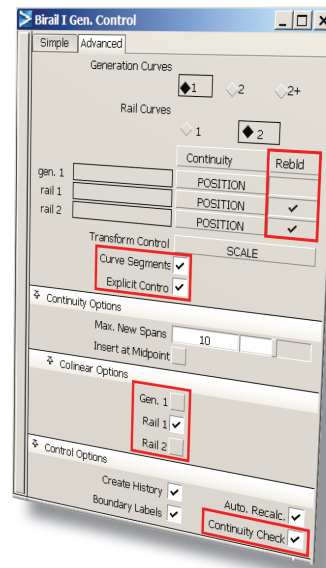
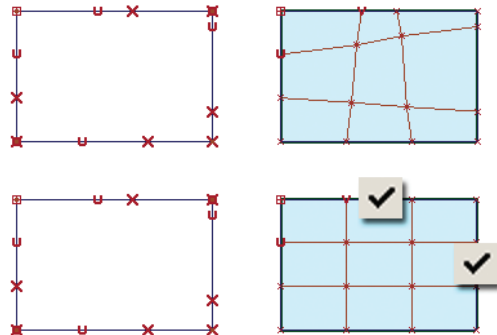

Curve Segments

Only available with one generation curve, the Curve Segments option gives you interactive control over how much of each rail curve is used to create the surface.

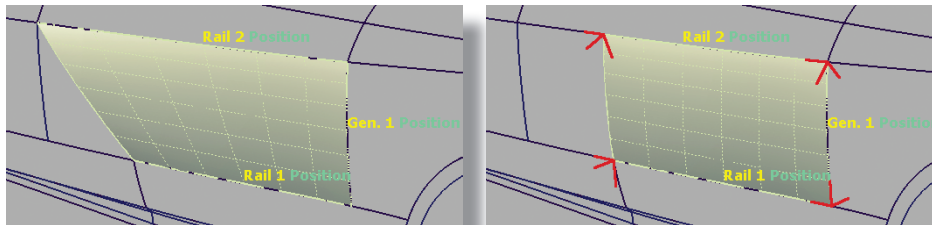

Colinear Options

Select the colinear option to align the CV directions of the surfaces, at each edge.

Be careful not to select these options when building to a trimmed edge, as the CV layout may be in a different orientation.

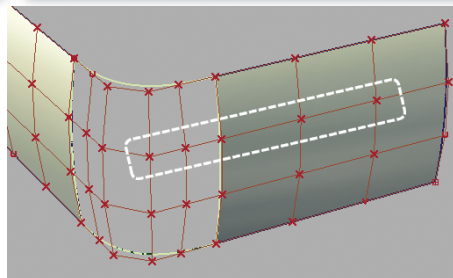

Understanding Data Organization

43

Layers / Lists

Layer Symmetry

Organizing Objects

Object Display

Saving Data

Data Transfer



Layers are the primary method of managing the geometry in your file. You create and name layers to suit the project you are working on, and then assign your geometry to the layers.

After the model is organized this way, you can use each layer to control the visibility, the symmetry display, the color and the selection state of the geometry assigned to it.

Layer Bar

The **Layers** menu is used to create, delete and manage layers, which are displayed in the Layer Bar at the top of the screen, just below the menus.



The first layer in the list is always the Default Layer, and it cannot be deleted. If there are no new layers, all geometry is placed on the Default layer.

Click a layer tab to make it the *active* layer. It is shown in yellow, and any new geometry is automatically placed onto it. Or simply assign geometry to the correct layers as required. To re-arrange the layers on the layer bar, use the middle mouse button to drag the layer tabs left or right. To scroll, use the arrows at the right end of the bar.

Layer Tab Menu

Each Layer tab has a sub-menu for assigning objects and turning the layer visibility on and off. The *Set State* sub-menu puts geometry into the background, *visible* but not *pickable*:

Pickable: normal working state.

Reference: geometry can be snapped to, but not selected.

Inactive: not selectable

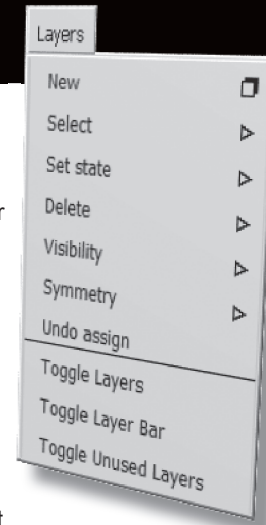
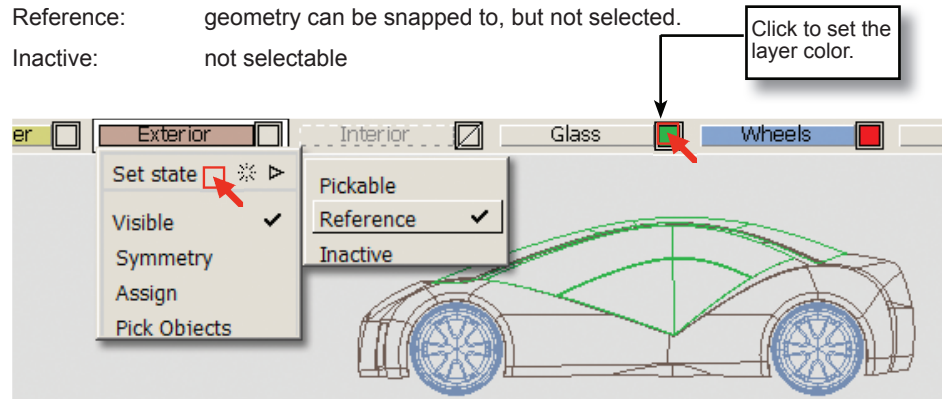

Layer Symmetry

To view a mirror-image of the geometry on a layer (shown with dotted lines), use *Symmetry* on the layer tab. The mirror direction defaults to car-line; to change it, use **Layer > Symmetry > Set Plane**.

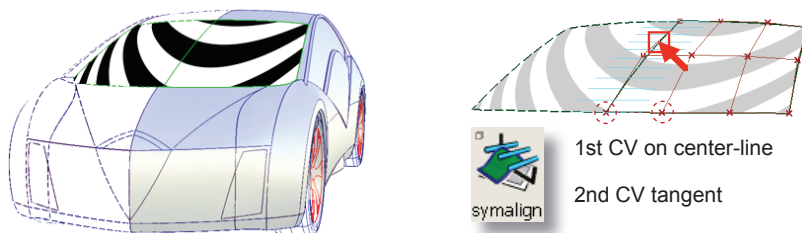

If symmetry is set up for a layer then *Object Edit > Symmetry Plane Align* can be used to ensure tangency along the center-line edge of the geometry.

Object Lister

An alternative to using the Layer bar is to use **Windows > Object Lister**. The default setting is *Show by Layers*, and each layer is listed with its submenu accessed using the right mouse button.

If you prefer this style of working, you can turn off the layer bar using **Layers > Toggle Layer Bar**.

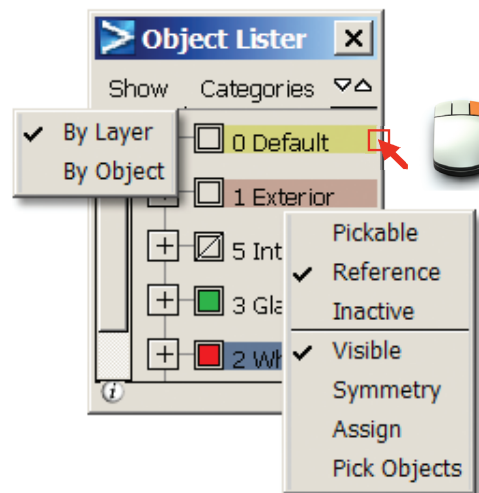

Layers versus ICEM Lists

Layers work slightly differently than Lists in ICEM, but they serve the same purpose.

There is no direct equivalent to the List DB. One item cannot be in two layers at the same time. So, if an object was in the Default Layer for example, it will no longer be there when you assign it to another layer.

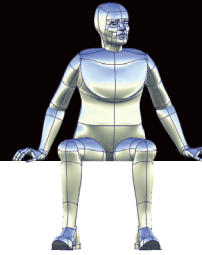

The functionality of the ICEM Object Editor is provided by two tools in AliasStudio: the **Object Lister** and the **Information Window**. The Object Lister is used here to explain how AliasStudio organizes the geometry in a file.

Atoms

There is no equivalent to the *atom* (patch/curve segment) and *molecule* (surface/curve) distinction used in ICEM. The smallest entities are simply called *curves* and *surfaces*, and these terms apply equally to single or multi-span geometry.

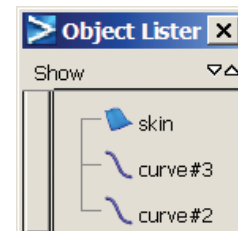

Molecules & Parts

Curves or surfaces can be *grouped* together to form a new *node*, which can be given a name, and selected as one object. This can be used in the same way that you group curve segments into curves in ICEM. The main difference is that a group can contain a mix of different entities.

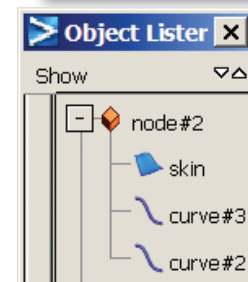

Like ICEM, AliasStudio doesn't create *assemblies*, instead, the **Edit > Group** tool can be used to simulate a structure of *parts*.

To select entities within a group, use **Pick > Component**, or **Edit > Ungroup** to return to independent entities.

Hierarchical Grouping

In this example of a mannequin model, each limb needs to be rotated to pose the model. For example, the lower leg surfaces need to behave like a single object, and be able to rotate around the knee. Grouping provides a single pivot point that allows all the surfaces in the lower leg to rotate as a single entity.

Here, groups have been made and carefully named, and then grouped again to form a complex hierarchy simulating the motion of the body. A simple example would be a car door.

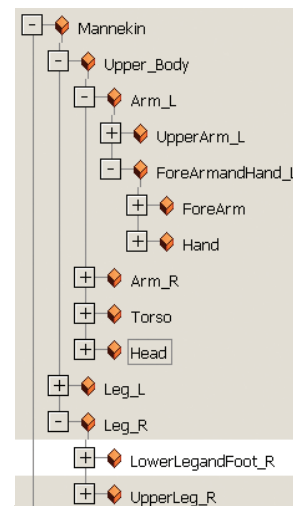
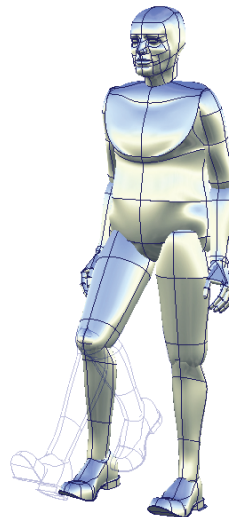

When modeling, it can be useful to quickly turn some geometry on or off, or put it into a background mode, without first organizing it onto layers. The Object Display window provides tools to temporarily control the display of objects.

Control

Mostly replaced by the *Display* section of the **Control Panel**, it is still useful for setting default preferences for the display of controls.

It is also the only place to control the display of Keypoints.

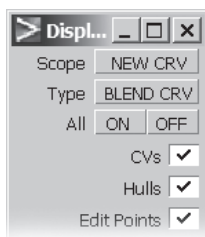

Invisible / Visible

This tool is used to make selected objects invisible. The Visible tool make all objects visible again. To control visibility per object, you can use the right mouse button in the **Object Lister**.

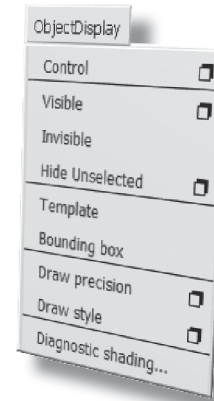
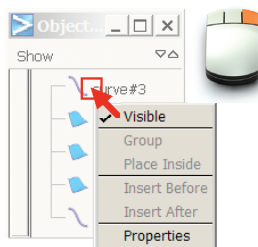

Hide Unselected

Allows you to select the object you want to view, and make all the others invisible. Use Object Display > Visible to return the object to the view, or use Utilities > Plug-in Manager to load the plug-in *toggleObjectInvisibility*

Template

Use with Pick > Object and Pick > Template to toggle geometry to and from a frozen (gray) state.

Other Useful Display Tools

Show menu on each window (shown right)

Control Panel > **Transparency** and **Quality** sections

Object Display > **Draw Style** : style of CV display:



Preferences > Interface > **User Colors** to modify the colors used for CVs, screen background etc.

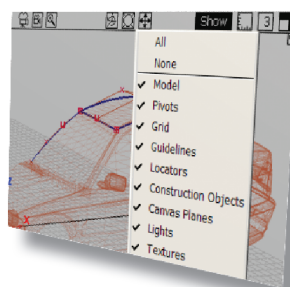

When you first use AliasStudio, a **user_data** directory is created. This is the recommended location for storing your data, using the project structure described below.

Note: you can use the browser window to store your data at a different location on your computer or network if required.

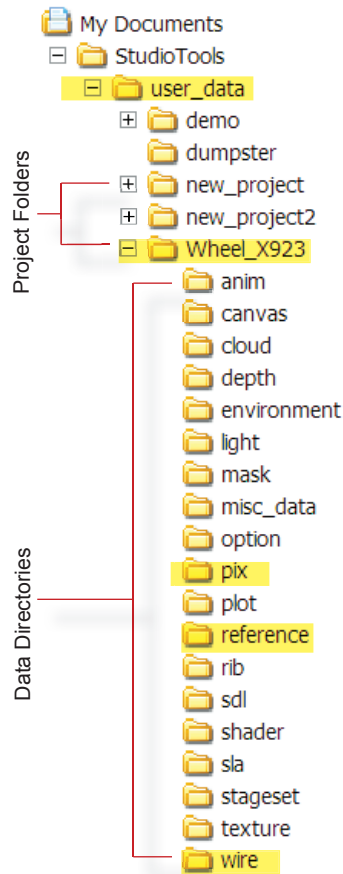

user_data

This is equivalent to the D:\DATABASE\SURF location in ICEMsurf. By default it contains the demo project, provided as a 'get started' working area, and the dumpster. This is rarely used – it manages the deletion of files through an old browser interface.

Project Folders

A project is simply a directory with sub-directories containing different data types. In the File Browser (accessed when you use File > Open or File > Save As), you can use the Project menu to create and manage project directories.

New Project creates a directory called new_project containing all the data sub-directories. Rename the directory for the job you are working on (e.g. Wheel_X923).

Set Current sets the selected project as the default save location, so that all related data for a project is stored in one place, including crash files.

Data Directories

Just like the eight directories in the ICEM Project Overview, AliasStudio stores different types of data in different sub-folders. The key folders are *wire* and *reference*, where geometry is stored, and *pix* for images.

Some of the folders created will never be filled – they relate to animation and rendering data (you can delete them).

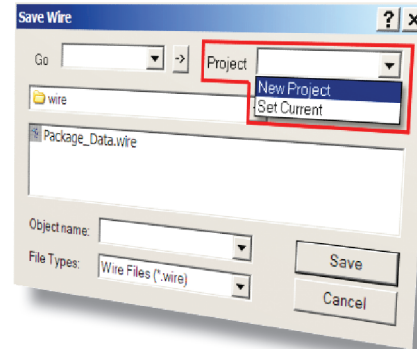

The AliasStudio geometry is in a format called *wire*, with a **.wire** file extension. This format can be used by AliasStudio to import other AliasStudio data only. For all other CAD systems you need to translate the data into one of the standard file formats.

Data Transfer

The IGES file format is the most universally used data format, and is best for translating data to and from ICEM. To export from AliasStudio, select the objects you want to transfer, use **File > Export > Active As...** to open the option window and select the IGES file format.

To import to AliasStudio, use File > Open or File > Import.

Unlike ICEM, there is no special sub-directory for IGES files; by default they are stored in the *wire* directory. It is a good idea, however, to create a new sub-folder to store and manage your IGES files.

As well as using industry standard formats such as IGES and STEP, some direct translation formats for common CAD systems are provided as purchasable options. For example, the CATV5 DirectConnect is a stand-alone utility that allows the exchange of 3D model data between AliasStudio and CATIA.

For more technical detail on data transfer, refer to the on-line help 'How To' section, or the *Data Transfer* PDF.

Reference Manager

File > Reference Manager does a similar job to the ICEM version. It can import large amounts of engineering data while maintaining interactive performance. It also can import large amounts of design data and provide alternative shading and comparisons for design reviews.

An AliasStudio **.wire** file is translated into a **.wref** format (similar to the EDF format in ICEM) and stored in the reference sub-directory in the project folder.

Auto Save

By default AliasStudio won't automatically save your data, so it is very important that you save your work regularly. You can choose to turn on an *Autosave* function using **File > Checkpoints**, but this shouldn't be used as a substitute for regular saving.

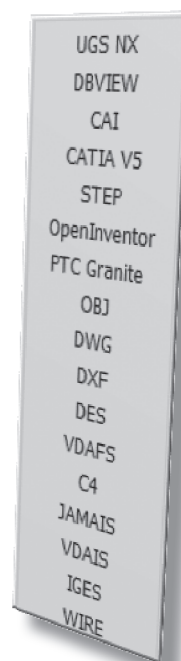

This brief guide has given you the key information to start using AliasStudio for technical surfacing tasks. We encourage you to use the on-line help and the PDF reference manuals to expand your knowledge as you gain hands-on experience with the software.

AliasStudio functionality covers a wide range of the design and development process. Your surfacing skills will give you an excellent starting point for working on fast concept development, or modeling in different industries, such as automotive, marine, product or packaging design.

Presentation and real-time viewing of designs has become a fundamental part of the design process. Exploring Hardware Shading in AliasStudio will add another dimension to your professional skills and provide great job satisfaction when you see your work presented at the highest quality. If you work in a large organization, you may want to look at the functionality of Autodesk's Showcase product which integrates with AliasStudio to provide full design review support.

We hope this booklet helps you overcome the inevitable frustrations of learning a new software package, and that you go on to enjoy developing your technical and creative expertise with AliasStudio.

For information on Training Courses please go to www.autodesk.com and choose **Services & Support > Product Training**.

3D View Mouse Constraints

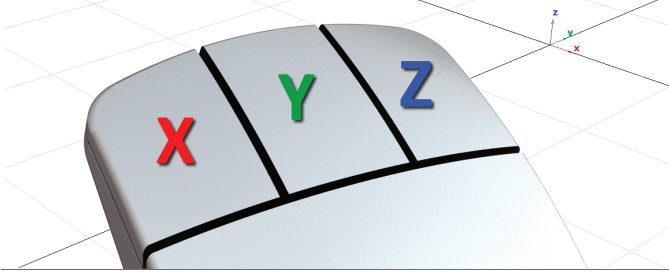

2D View Mouse Constraints

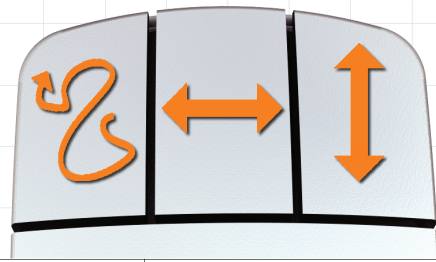

Viewing

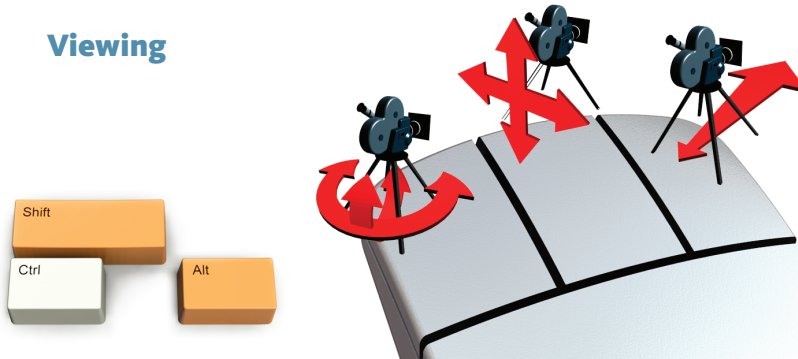

Marking Menu

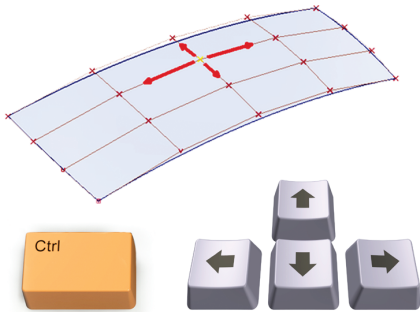

Pick Walk

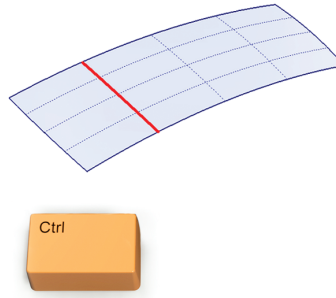

UV Snapping (1.0)

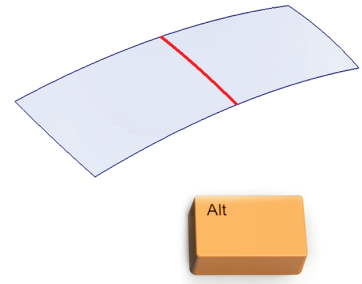

UV Snapping (0.5)

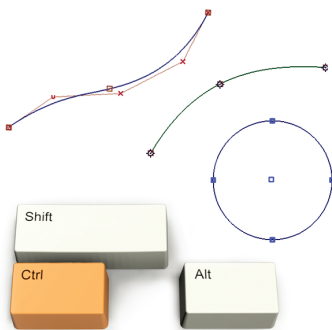

Point Snap

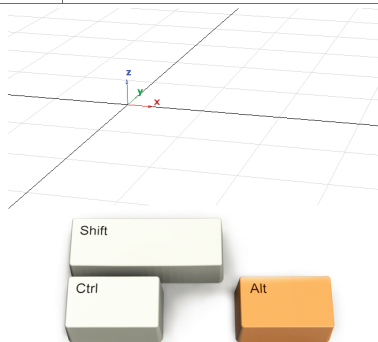

Grid Snap

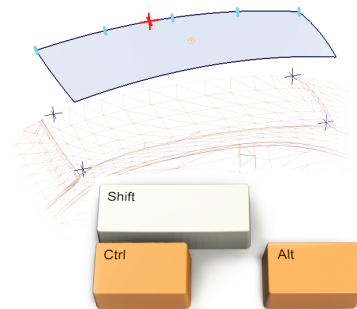

Curve Snap